

JBM-100-STB

NEMA 4X-rated connection kit Installation Instructions

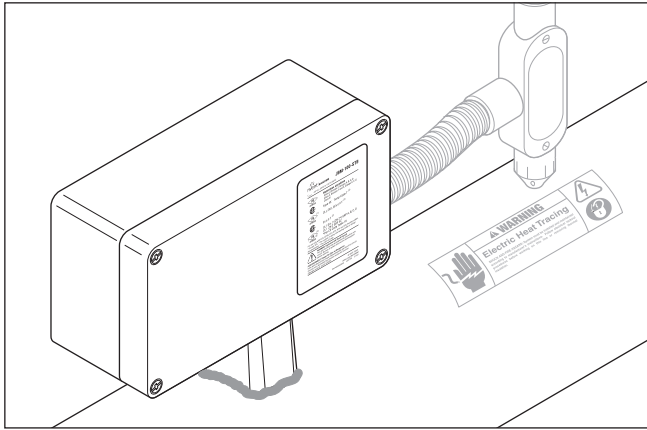

Power Connection, Powered Splice, Powered Tee, Dual Power Connection, Splice or Tee with Junction Box

DESCRIPTION

The nVent RAYCHEM JBM-100-STB is a NEMA 4X-rated connection kit. It is designed for use with nVent RAYCHEM BTV-CR, BTV-CT, QTVR-CT, XTV(R)-CT, KTV-CT, HTV-CT and VPL-CT industrial parallel heating cables. The kit can be used to connect one, two, or three heating cables to power, to connect two separate heat-trace circuits, or to splice or tee up to three heating cables.

Note: For two or more heating cables powered by a single circuit, the length of each heating cable should not exceed the maximum allowable circuit length published in the nVent RAYCHEM self-regulating cables design guide and the total current of all heating cables on the circuit should equal no more than 80% of the circuit breaker current rating.

The JBM-100-STB utilizes screw terminal blocks to make electrical connections.

These kits may be installed at temperatures as low as -67°F (-55°C), and the maximum ambient temperature of 132°F (56°C). For easier installation store above freezing until just before installation.

For technical support call your local nVent representative.

TOOLS REQUIRED

- Marking pen
- Wire cutters
- Utility knife
- Large slotted screwdriver
- Needle nose pliers
- Adjustable pliers
- Wire stripper (for VPL-CT)
- ¼ in or smaller slotted screwdriver
- ⅜ in hex key (required for splice and tee connections)

ADDITIONAL MATERIALS REQUIRED

- Pipe strap
- GT-66 or GS-54 glass cloth tape



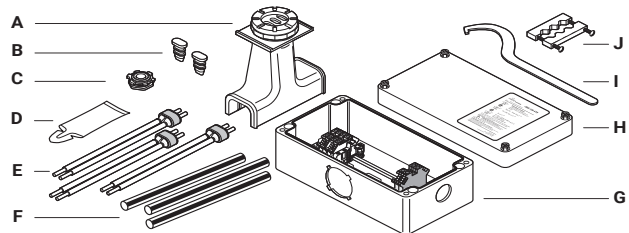

OPTIONAL MATERIALS

- Recommended conduit drain: JB-DRAIN-PLUG-3/4IN P/N 278621-000
- Small pipe adapter for 1 in (25 mm) and smaller pipes: Catalog number JBM-SPA P/N D55673-000



APPROVALS

Hazardous Locations

-  (1) Class I, Div. 2, Groups A, B, C, D
Class II, Div. 1 and 2, Groups E, F, G
Class III
-  (1) Temp Code*
-  (2) Class I Division 2 (Zone 2**), Groups A, B, C, D
-  CL I ZN 1 AEx eb IIC T* Gb
ZN 21 AEx tb IIIC T* C Db
Ex eb IIC T* Gb
Ex tb IIIC T* C Db

* For system Temperature Code, see heating cable or design documentation
(1) Except HTV
(2) For HTV-CT only ** Per CE Code Table 18

KIT CONTENTS

Item	Qty	Description
A	1	Stand assembly
B	2	Grommet plugs
C	1	Box plug, o-ring, and locknut
D	1	Cable lubricant
E	3	Core sealers
F	3	Green/yellow tubes
G	1	Box with terminals (max: ¾" conduit & 8 AWG wire)
H	1	Lid
I	1	Spanner
J	1	Strain relief

WARNING:

This component is an electrical device that must be installed correctly to ensure proper operation and to prevent shock or fire. Read these important warnings and carefully follow all of the installation instructions.

- To minimize the danger of fire from sustained electrical arcing if the heating cable is damaged or improperly installed, and to comply with the requirements of nVent, agency certifications, and national electrical codes, ground-fault equipment protection must be used. Arcing may not be stopped by conventional circuit breakers.
- The power connection may be powered by more than one circuit. Be sure all power sources are de-energized before opening box.

- Component approvals and performance are based on the use of nVent-specified parts only. Do not use substitute parts or vinyl electrical tape.
- The black heating cable core and fibers are conductive and can short. They must be properly insulated and kept dry.
- Damaged bus wires can overheat or short. Do not break bus wire strands when scoring the jacket or core.
- Keep components and heating cable ends dry before and during installation.
- Use only fire-resistant insulation materials, such as fiberglass wrap or flame-retardant foam.

AVERTISSEMENT :

Ce composant électrique doit être installé correctement pour éviter les risques d'incendie ou de chocs électriques. Lire ces avertissements importants et suivre attentivement toutes les instructions d'installation.

- Pour réduire le danger d'incendie causé par un arc électrique entretenu, si le câble chauffant est endommagé ou mal installé, et pour respecter les exigences de nVent et celles des codes applicables, il est impératif d'utiliser une protection par disjoncteur différentiel. Les disjoncteurs ordinaires ne sont pas toujours capables de supprimer les arcs électriques.
- Les approbations et les performances des composants sont basées sur l'utilisation des pièces nVent spécifiées seulement. N'utilisez pas de pièces de rechange ou de ruban isolant en vinyle.

- Le noyau et les fibres du câble chauffant noir sont conducteurs et peuvent provoquer un court-circuit. Ils doivent être correctement isolés et gardés à sec.
- Les fils omnibus endommagés peuvent surchauffer ou subir un court-circuit.
- Ne brisez jamais les fils omnibus lorsque vous incisez la gaine ou le noyau.
- Maintenez les composants et les extrémités des câbles chauffants secs avant et pendant l'installation.
- Les fils omnibus peuvent provoquer un court-circuit s'ils se touchent. Les garder à l'écart les uns des autres
- N'utilisez que des matériaux isolants ininflammables, par exemple une gaine de fibre de verre ou de la mousse ignifuge.
- Laissez ces instructions d'installation à l'utilisateur pour qu'il puisse les consulter.

CAUTION:

Health Hazard: Prolonged or repeated contact with the sealant in the core sealer may cause skin irritation. Wash hands thoroughly. Overheating or burning the sealant will produce fumes that may cause polymer fume fever. Avoid contamination of cigarettes or tobacco. Consult MSDS VEN 0033 for further information.

CHEMTREC 24-hour emergency telephone: (800) 424-9300

Non-emergency health and safety information: (800) 545-6258.

MISE EN GARDE :

Danger pour la santé : Le contact prolongé ou répété avec le produit d'étanchéité du noyau peut provoquer une irritation de la peau. Lavez-vous les mains soigneusement. La surchauffe et la combustion du produit d'étanchéité produira des vapeurs qui peuvent causer la fièvre des vapeurs de polymères. Évitez la contamination des cigarettes ou du tabac. Consultez la fiche technique santé-sécurité (FTSS) VEN 0033 pour obtenir de plus amples informations.

Téléphone en cas d'urgence 24 heures sur 24 de CHEMTREC : (800) 424-9300

Renseignements non urgents en matière de santé et de sécurité : (800) 545-6258

Heating Cable Types

- Determine heating cable type and continue as shown.

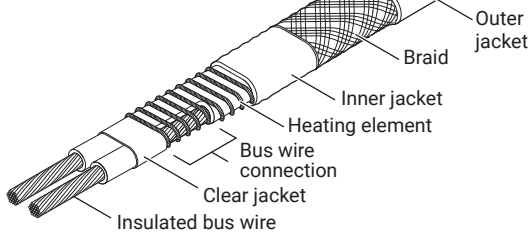

VPL
Go to Step 1A

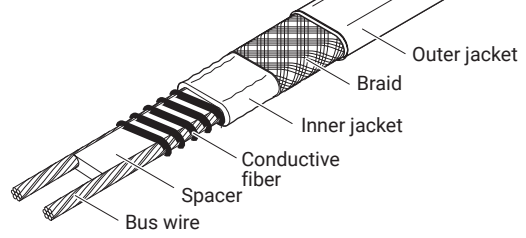

XTV(R)-CT, KTV-CT
Go to Step 1B

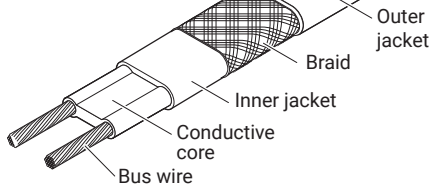

BTV-CR, BTV-CT, QTVR-CT
Go to Step 1B

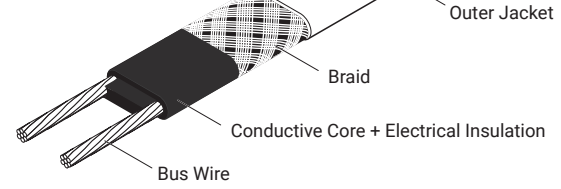

HTV-CT
Go to Step 1B

1A

VPL

- Cut each heating cable 12 in (30 cm) from the center of the first indentation, cut at a 45° angle.

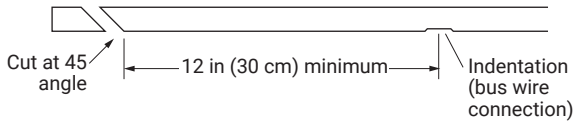

- After heating cable has been cut, align indentations. Allow approximately 24 in (60 cm) of heating cable for installation.

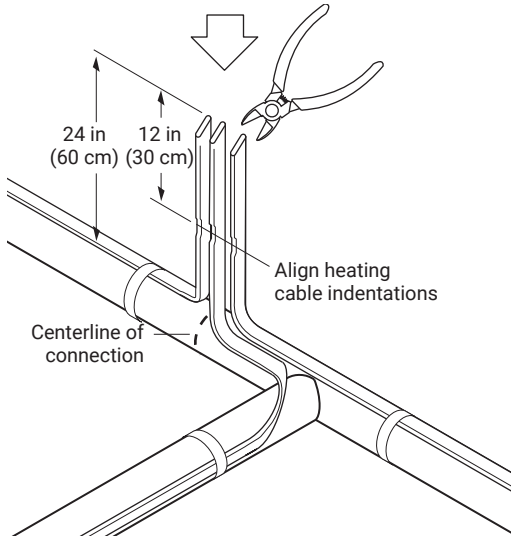

Go to Step 2

1B

BTV, QTVR, XTV(R), KTV, HTV

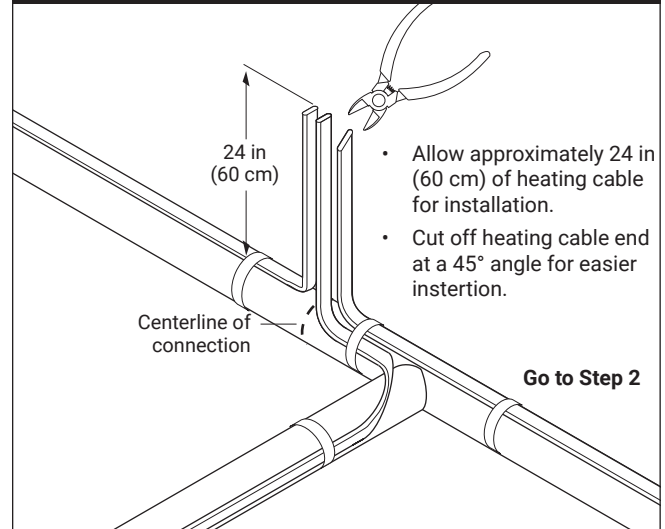

- Allow approximately 24 in (60 cm) of heating cable for installation.
- Cut off heating cable end at a 45° angle for easier insertion.

Go to Step 2

2

Complete steps 2 through 6 for each heating cable before going on to the next length of heating cable.

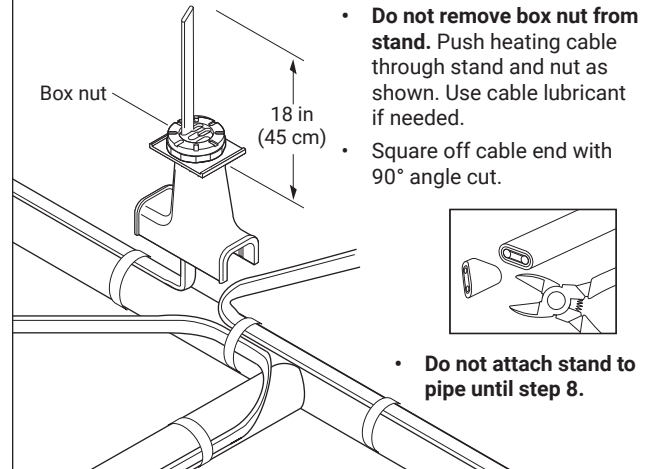

- **Do not remove box nut from stand.** Push heating cable through stand and nut as shown. Use cable lubricant if needed.
- Square off cable end with 90° angle cut.

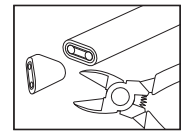

- **Do not attach stand to pipe until step 8.**

3

- Lightly score outer jacket around and down as shown.
- Bend heating cable to break jacket at score, then peel off jacket.

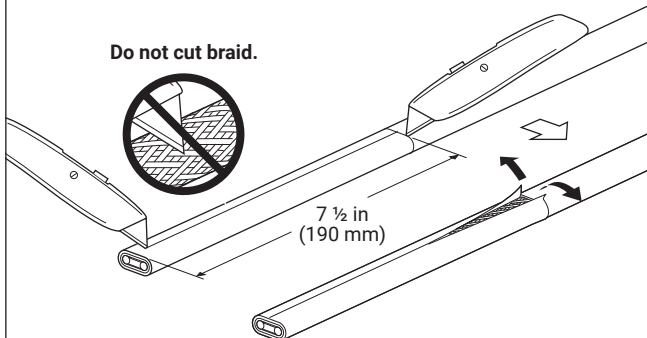

4

- Determine heating cable type and continue as shown.

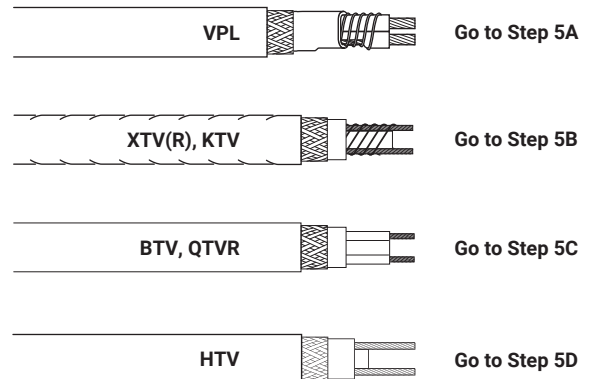

5A

VPL

- Push braid back and bunch as tight as possible.

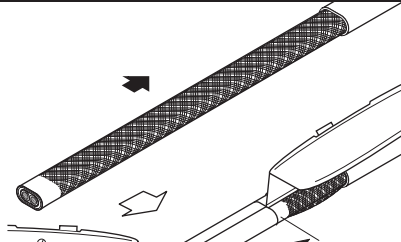

- Lightly score inner jacket around and down as shown.

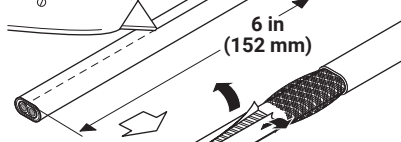

- Peel off inner jacket.



- Unwind heating element, cut and remove as shown.

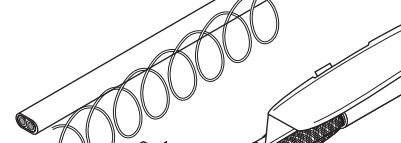

- Lightly score clear jacket around and down as shown.

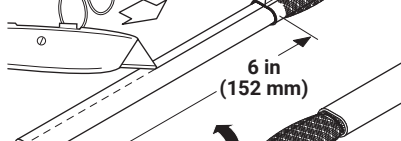

- Bend heating cable to break jacket at the score then peel off jacket.



- Push braid forward. Use a screwdriver to open braid.

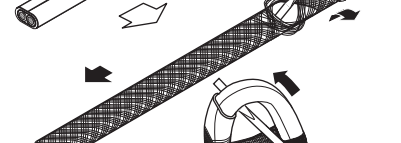

- Bend heating cable and work it through opening in braid.

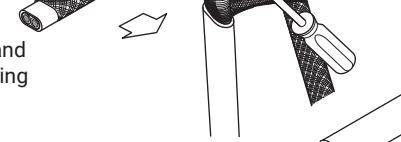

- Remove insulation from ends of bus wires.

- Pull braid tight to make pigtail.

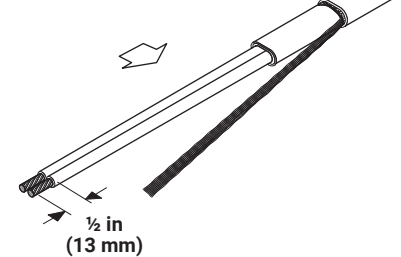

Go to Step 6

5B

XTV(R), KTV

- Push braid back to create a pucker.
- At pucker use a screwdriver to open braid.

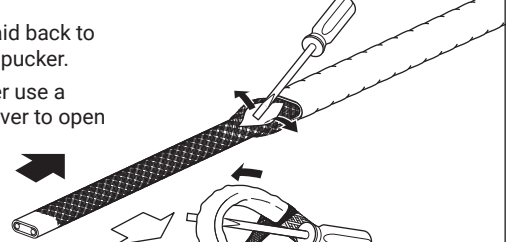

- Bend heating cable and work it through opening in braid.



- Lightly score inner jacket around and down as shown.



- Peel off inner jacket.

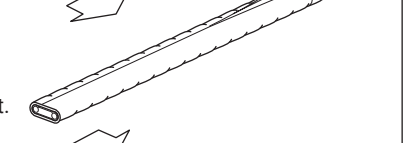

- Cut and remove all fiber strands.



- Score and remove center spacer.

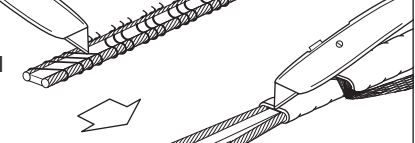

- Remove any remaining fiber material from bus wires.

- Pull braid tight to make pigtail.

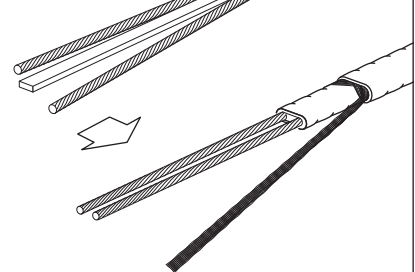

Go to Step 6

5C

BTV, QTVR



- Push braid back to create a pucker.
- At pucker use a screwdriver to open braid.

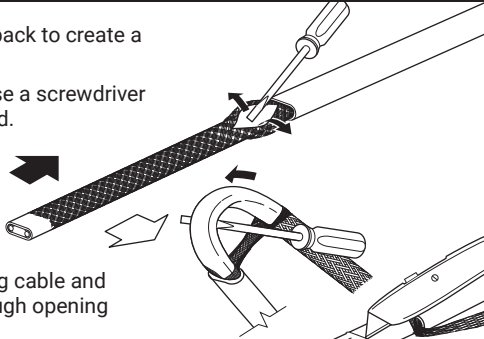

- Bend heating cable and work it through opening in braid.

- Lightly score inner jacket around and down as shown.

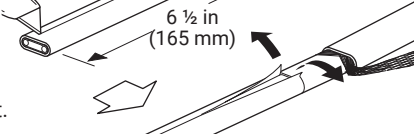

- Peel off inner jacket.

- Notch core.

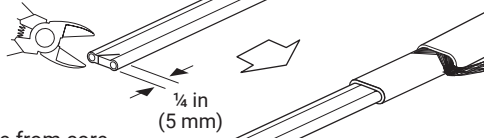

- Peel bus wire from core.

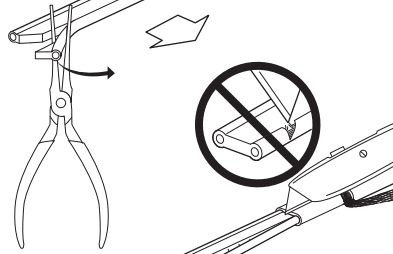

- Score core between bus wires at inner jacket.

- Bend and snap core.

- Peel core from bus wire.

- Remove any remaining core material from bus wires.

- Pull braid tight to make pigtail.

Go to Step 6

5D

HTV

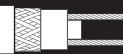

- Push braid back to create a pucker.
- At pucker use a screwdriver to open braid.

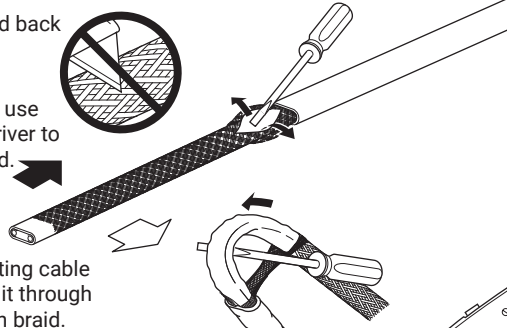

- Bend heating cable and work it through opening in braid.

- Score inner jacket and conductive core around and down as shown.

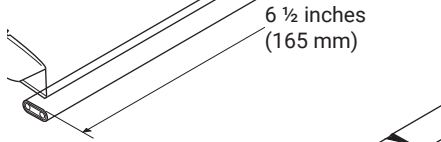

- Peel off inner jacket.

- Flip the cable 180° and score the other side of inner jacket and conductive core.

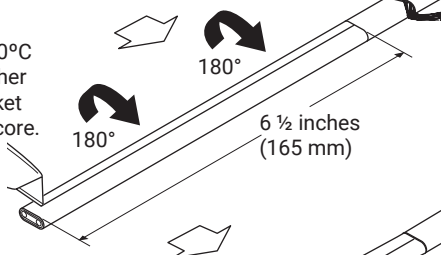

- Remove the inner jacket, conductive core by using needle-nose pliers as shown.

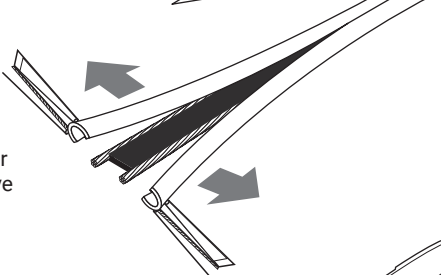

- Score and remove center insulation.

- Remove any remaining material from bus wires.

- Pull braid tight to make pigtail.

Go to Step 6

6

- Mark the jacket as shown.

5/8 in (15 mm)

7

- Pull heating cable back into stand as shown. Use cable lubricant if needed.
- Repeat steps 2 through 7 for other heating cables before continuing to step 8.

1 1/4 in (32 mm)

8

- Fasten stand to pipe. Do not pinch heating cables.
- Loop and tape extra heating cable to pipe.

Note: For 1 in (25 mm) and smaller pipes, use adapter (purchased separately) and install between stand and pipe.

Pipe strap
Glass cloth tape

8A

JBM-SPA adapter for small pipes
Position adapter this side up.

≥120 mm & ≤180 mm
JBM-100-STANDOFF P000003624

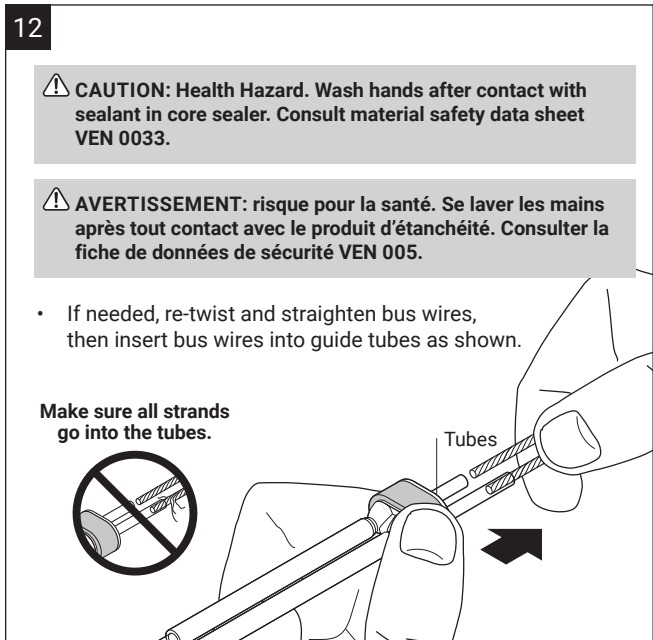
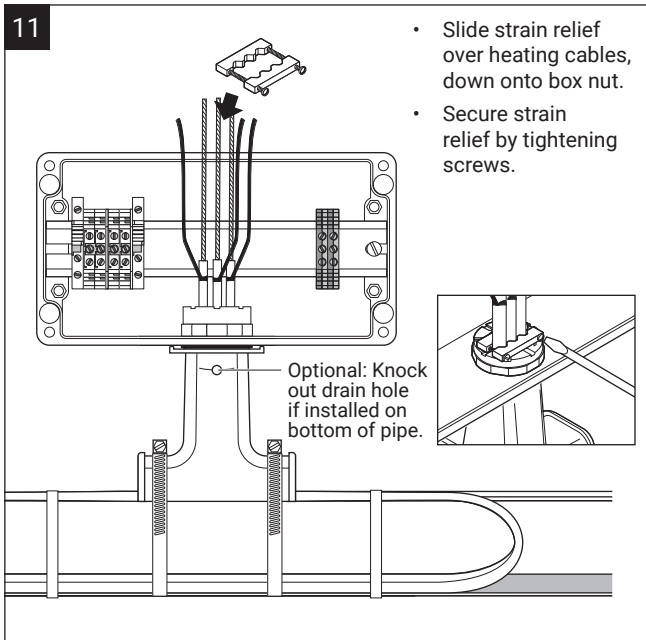
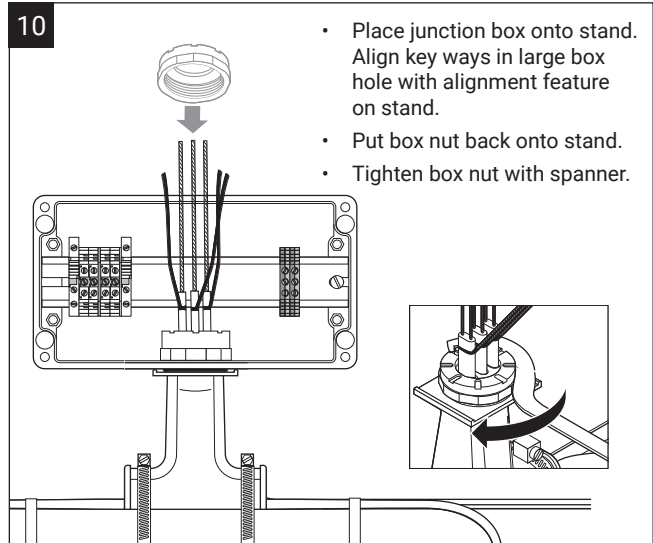
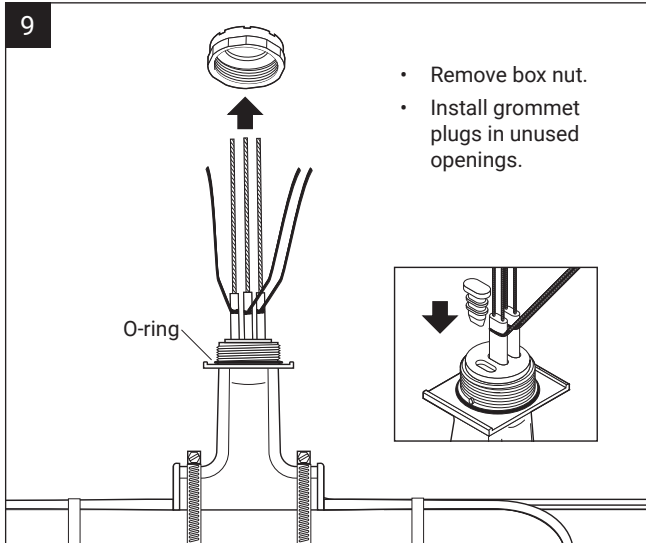

13

- Push core sealer onto the heating cable to the mark made in step 6.

Note: Extra force may be required for larger cables or at lower temperatures.

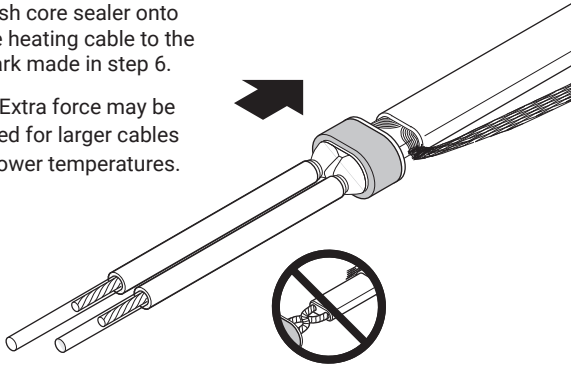

Make sure the bus wires do not kink, bunch, or crossover.

14

- Remove the guide tubes and dispose of them in a plastic bag.
- Slip the green/yellow tube onto the braid.

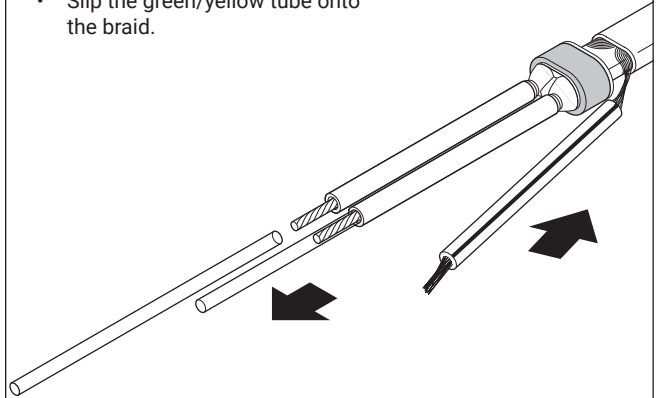

15

- Trim bus wires and braid.
- Repeat steps 12 through 15 for all heating cables.

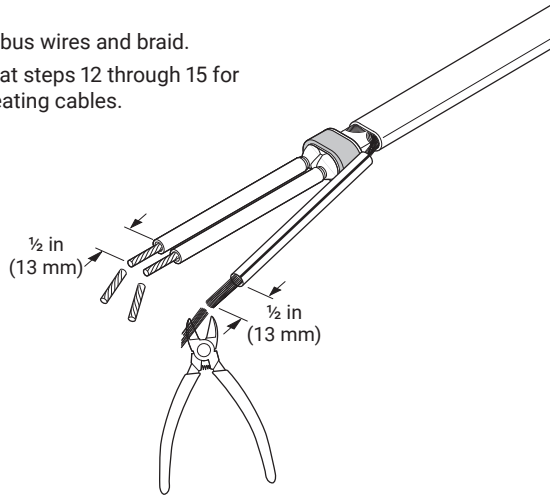

16

Finished view of installed core sealers.

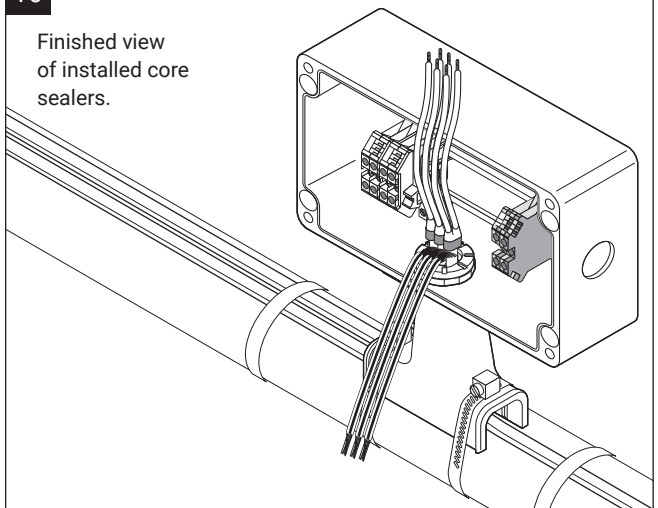

This kit uses screw style terminals.

To connect wires, fully insert into opening on side of terminal block ①. Insert small flat-blade screwdriver through round opening and firmly tighten screw ②.

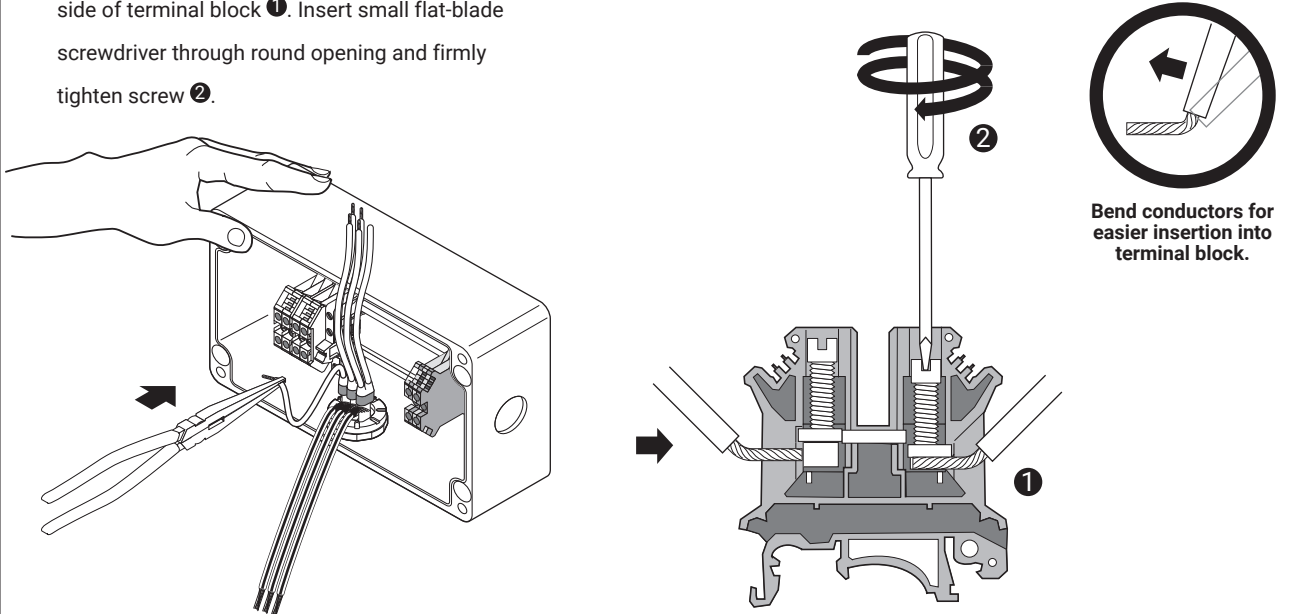

Bend conductors for easier insertion into terminal block.

- Wire insertion ①.
- Refer to wiring diagram, step 18A, 18B, or 18C.

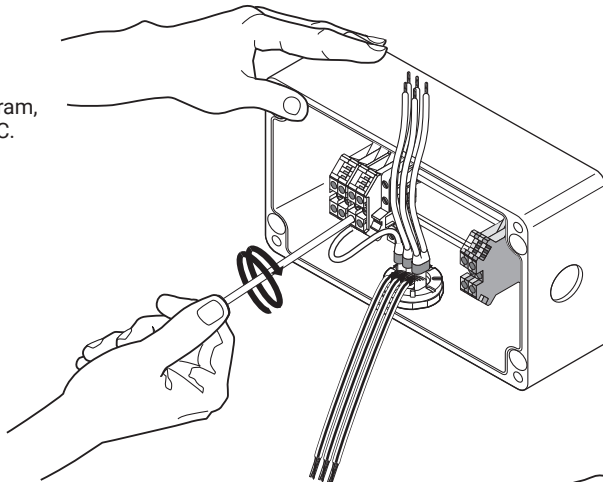

- Tighten screws ②.
- Use green terminal for braid and ground wires.

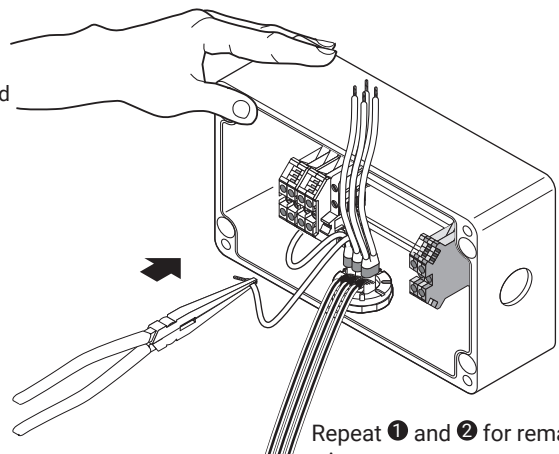

Repeat ① and ② for remaining wires.

18A Splice Wiring

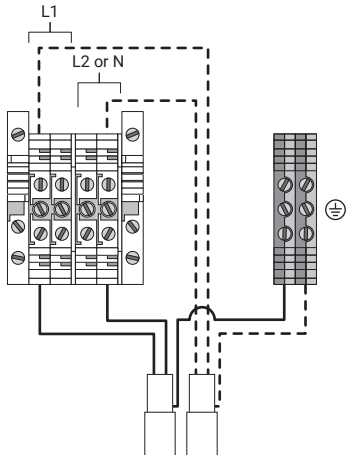

18B Tee Wiring

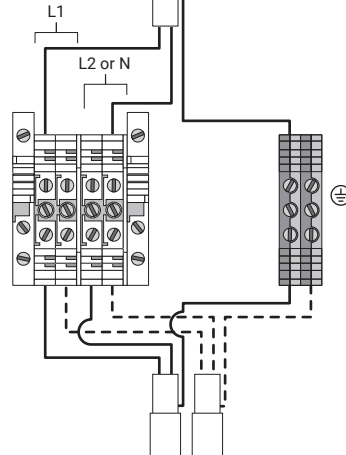

18C Power Connection Wiring

⚠ WARNING: Shock Hazard. When the power connection is energized by two circuits, the L1 and L2 jumpers must be removed to prevent an electrical short.

⚠ AVERTISSEMENT: risque d'électrocution et d'incendie. Lorsque le raccordement électrique est alimenté par deux circuits, les cavaliers L1 et L2 doivent être enlevés afin d'éviter un court-circuit.

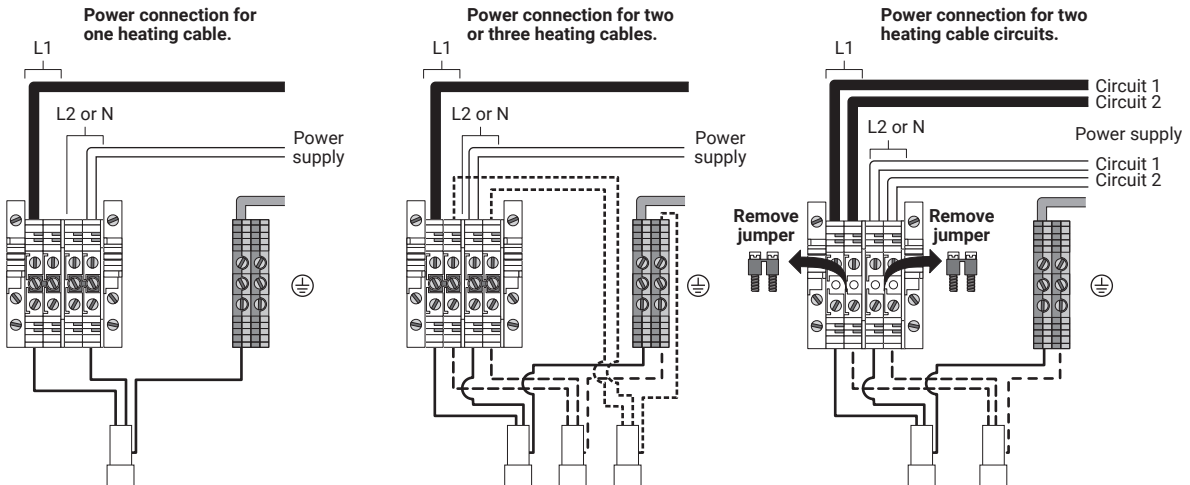

19A If used as a power connection

- Install conduit and fittings as shown. To minimize loosening due to vibration, use flexible conduit.
- Pull in power and ground wires, strip off insulation, and terminate.

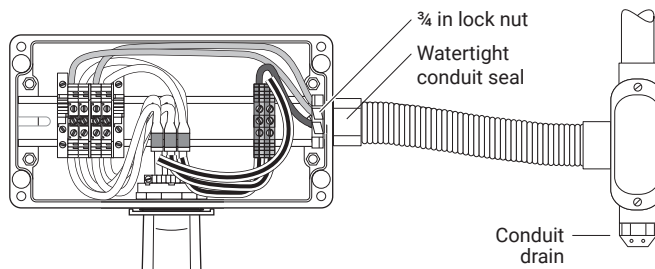
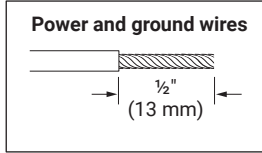

Make sure conductors are not exposed.

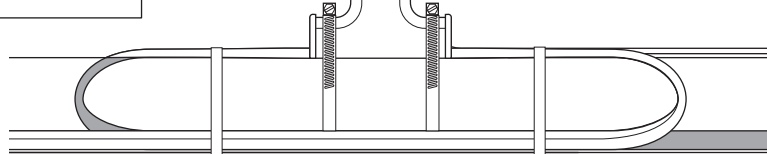

- nVent recommends the use of a conduit drain to prevent water condensation build-up.

19B If used as a splice or tee connection

- Install box plug.

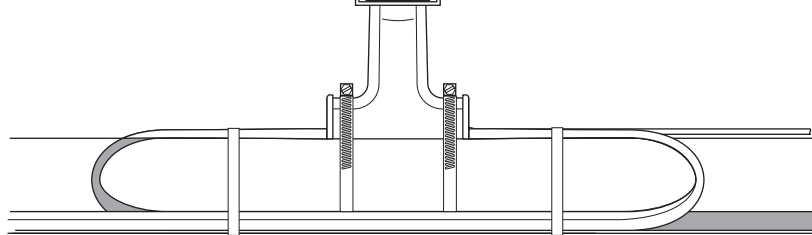
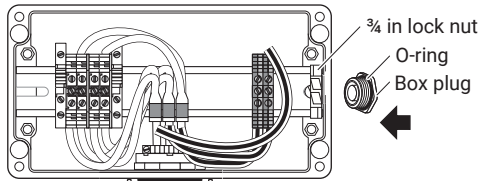

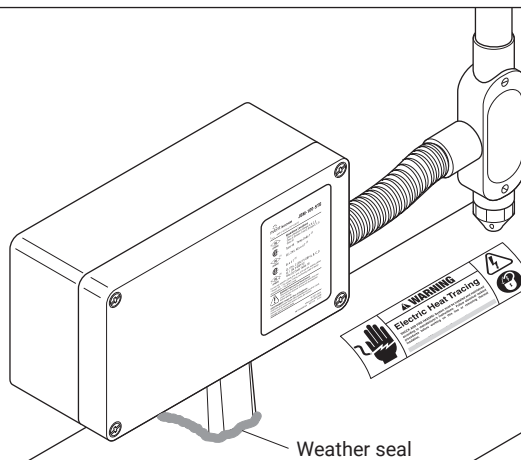

20

- Install lid. Torque = 1.02 to 1.47 Nm
- Apply insulation and cladding.
- Weather-seal the stand entry.
- Leave these instructions with the end user for future reference.



 **WARNING: Explosion Hazard- Substitution of components may impair suitability for Class i Division 2 (Zone 2)**

 **AVERTISSEMENT: Risque d'explosion. La substitution de composants peut rendre ce matériel inacceptable pour les emplacements de Classe i, Division 2 (Zone 2).**

 **WARNING: Explosion Hazard- Do not disconnect equipment unless power has been switched off or the area is known to be non-hazardous.**

 **AVERTISSEMENT: Risque D'explosion. Ne pas débrancher l'appareil à moins d'avoir coupé l'alimentation électrique ou à moins qu'il ne s'agisse d'un emplacement non dangereux**

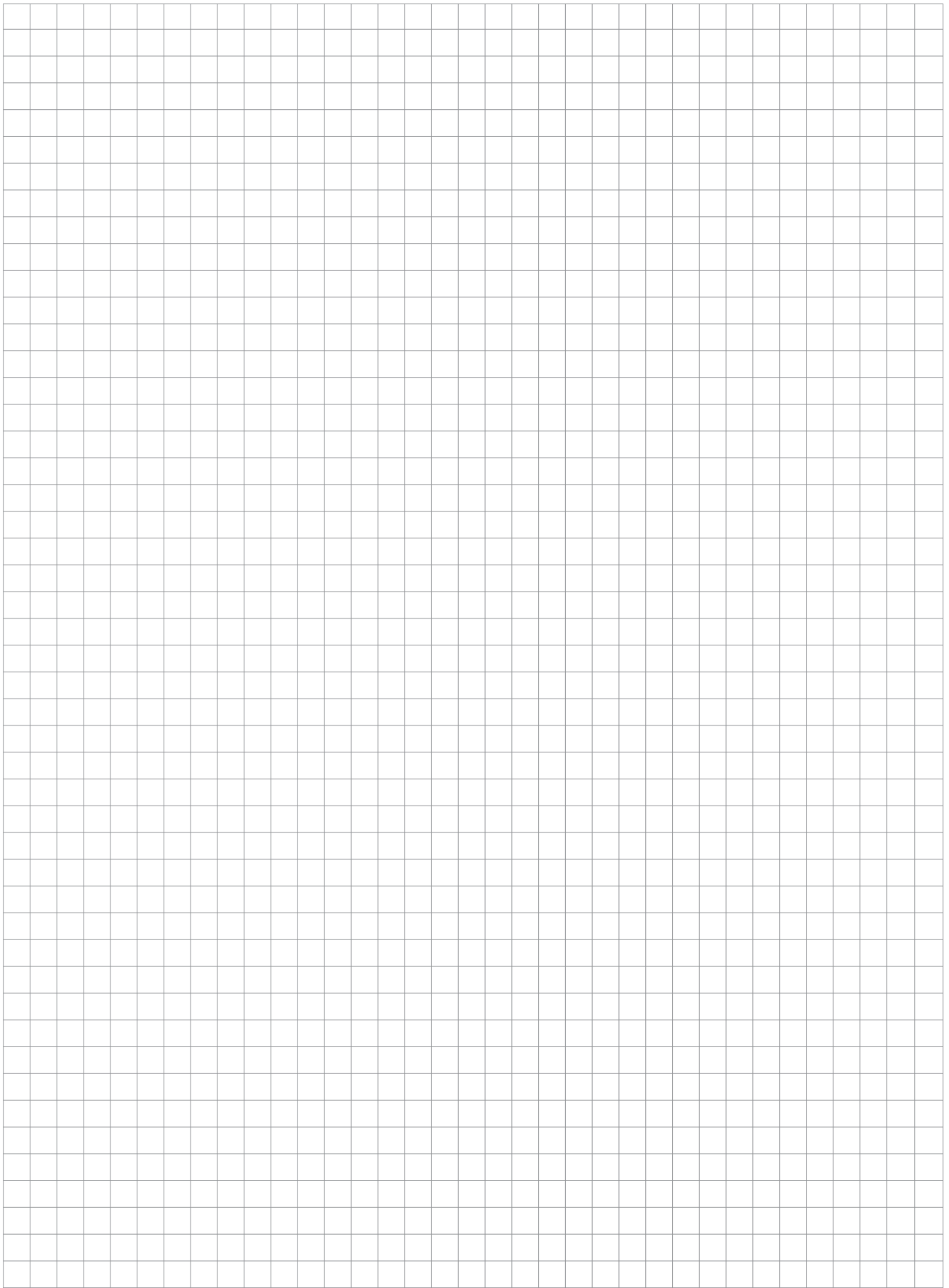

North America

Tel +1.800.545.6258
Fax +1.800.527.5703
thermal.info@nVent.com

Europe, Middle East, Africa

Tel +32.16.213.511
Fax +32.16.213.604
thermal.info@nVent.com

Asia Pacific

Tel +86.21.2412.1688
Fax +86.21.5426.3167
cn.thermal.info@nVent.com

Latin America

Tel +1.713.868.4800
Fax +1.713.868.2333
thermal.info@nVent.com



[nVent.com/RAYCHEM](https://www.nVent.com/RAYCHEM)