

**Submitted to:** Pentair

**Title:** New Calculations of Weld Size for C2, C3J, CADWELD B, P9J, C13 and C14 Couplers

**Introduction:** Pentair fabricates parts that connect reinforcing bar to structural steels. Several of these coupler series connect reinforcing bar to a supporting member face perpendicular to the axis of the bar. The C2, C3J, CADWELD B, P9J, C13, and C14 couplers all are connected to the supporting member face with partial penetration groove and fillet welds.

**Objective:** The objective of this project is to provide Pentair with weld size recommendations for the C2, C3J, CADWELD B, P9J, C13, and C14 coupler series based on AWS D1.1 – Structural Welding Code – Steel.

**Approach:** By referencing AWS D1.1:2015 – Structural Welding Code – Steel, EWI, in this report, makes recommendations for weld sizes for the C2, C3J, CADWELD B, P9J, C13, and C14 part attached to steel plate.

**Assumptions:** The forces supplied for the rebar are based on the minimum allowable yield strength and ultimate strength values for ASTM A615:2016 Grades 60 and 80 rebar for the ACI318:2014 Type I and Type II forces. These forces  $F_r$  are listed in Table 1. The AWS D1.1 design approach for welds is designed to prevent through section yielding of the weld areas under the peak loading from such forces.

**Table 1. Rebar Forces**

		<b>ASTM A615 Grade 60 (Note 1)</b>	
<b>Rebar Size No.</b>	<b>Rebar Size Metric (mm)</b>	<b>ACI Type I Force (lbf)</b>	<b>ACI Type II Force (lbf)</b>
3	10	8,250	9,900
4	12	15,000	18,000
	14	18,000	21,600
5	16	23,250	27,900
	18	29,250	35,100
6	20	33,000	39,600
7	22	45,000	54,000
8	25	59,250	71,100
9	28	75,000	90,000
	30	82,500	99,000
10	32	95,250	114,300
	34	105,750	126,900
11	36	117,000	140,400
12	38	132,000	158,400
	40	146,250	175,500
14	43	168,750	202,500
	50	228,000	304,000
18	57	300,000	400,000

Note 1: ASTM A615 grade 60 equals or exceeds the force of ASTM A706 grade 60.

		<b>ASTM A615 Grade 80 (Note 2*)</b>	
<b>Rebar Size No.</b>	<b>Rebar Size Metric (mm)</b>	<b>ACI Type I Force (lbf)</b>	<b>ACI Type II Force (lbf)</b>
3	10	11,000	11,550
4	12	20,000	21,000
	14	24,000	25,200
5	16	31,000	32,550
	18	39,000	40,950
6	20	44,000	46,200
7	22	60,000	63,000
8	25	79,000	82,950
9	28	100,000	105,000
	30	110,000	115,500
10	32	127,000	133,350
	34	141,000	148,050
11	36	156,000	163,800
12	38	176,000	184,800
	40	195,000	204,750
14	43	225,000	236,250
	50	304,000	319,200
18	57	400,000	420,000

Note 2: A615 grade 80 equals or exceeds the force of ASTM A615 grade 75 and ASTM A706 grade 80.

The welds are assessed as partial-penetration groove and fillet weld combinations for all couplers. The loading is assumed to be a single event axial tension loading applied axially by the rebar perpendicular to the face of the supporting member. Calculations are provided for the size of the fillet weld, assuming that the full weld bevel is filled. Stresses have also been calculated along the coupler adjacent to the weld and on the face of the supporting member.

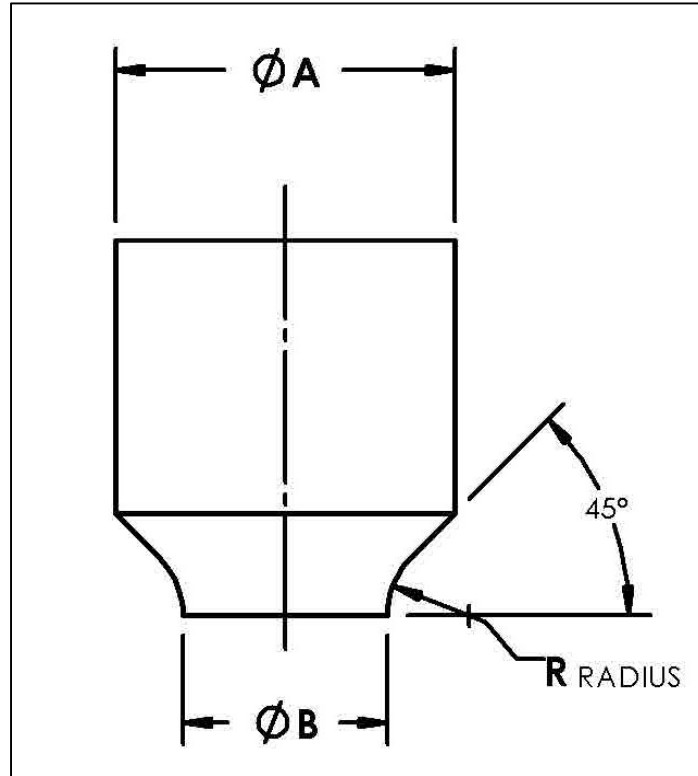

**Figure 1. Weld Bevel Configuration for Couplers**

Full penetration to the root of the weld bevel is assumed. Some welding processes or orientations may not allow full penetration to the root, but this is not common for cases with a root radius as shown in Figure 1. In cases where the penetration does not reach the root, an increase of fillet leg length of 1/8 in. should be applied.

Stresses in the weld are assumed to be well described by shear on the weld throat (AWS 2.5.4 and 2.5.4.1). Stress in the coupler adjacent to the weld is assumed to be well described by shear on an effective throat from the weld root to the weld tow on the coupler. Stress in the face of the supporting member is assumed to be well described by uniform tension.

The limiting stresses for design are based on the minimum tensile strength for the weld metal  $\sigma_{Uw}$  (70 ksi), the minimum yield strength of the coupler  $\sigma_{Yc}$  and the minimum yield strength of the supporting member  $\sigma_{Yf}$ .

**Calculations:** The calculations are done in two steps. First, the weld sizes are calculated based on weld throat for an equal leg fillet. Then, the unequal leg fillet is considered. A larger fillet leg on the coupler side increases strength for the case where stresses are limiting on the coupler side.

The effective weld throat for groove and fillet weld combinations is determined by the minimum distance between the root and the weld cap, not including any convexity (AWS D1.1 Annex A and 2.4.2.7).

The effective weld area is the effective weld throat times the effective weld length (AWS D1.1 2.4.1.5 and 2.4.2.10). This is calculated based on the area of the surface of a frustrum cone between the weld root and the weld toe of the fillet weld.

The determination of the weld sizes utilized the alternative allowable fillet weld stress provision 2.6.4.4, since the stresses assessed were considered as shear on the weld throat and the loading is centered at the center of the coupler. The words of the provision are as follows:

*“2.6.4.4 **Concentrically Loaded Weld Groups.** Alternatively, for the special case of a concentrically loaded weld group, the allowable shear stress for each weld element may be determined using formula (2) and the allowable loads of all elements calculated and added:*

*Formula (2)  $F_v = 0.30 C F_{EXX}$*

*Where*

*$F_v$  = allowable unit stress.*

*$F_{EXX}$  = nominal tensile strength of filler metal*

*C = the equivalent strength coefficient for obliquely loaded fillet weld, chosen from Table 2.4.”*

It may be noted that the application of this provision rather than the normal criteria in AWS D1.1 Table 2.3 requires a judgment that the groove and fillet welds here are applicable cases and that the curved weld in the design can be assessed as locally linear because it has a well-defined value of  $\theta$ , the angle between the direction of loading and the axis of the weld at a particular location. **An appendix is provided for determination of weld size for cases where the alternative allowable sizes are not used, such as older versions than AISC 360:2016 Specification for Design, Fabrication, and Erection of Structural Steel for Buildings, and AISC N690:2015 Specification for Safety-Related Steel Structures for Nuclear Facilities.**

Also the provision for allowable stress increase in AWS D1.1 2.6.5 can be used, since many codes of construction allow larger stresses for base metal under special conditions. This allows an increase for all parts of the weld area, including both base metals and the weld metal.

Shear is assessed on the base metal of the coupler adjacent to the weld, defining the throat of this section based on the frustrum cone from the weld root to the weld toe on the coupler.

The direct tension stress on the face of the support member can also be a limiting factor. This stress is calculated as a uniform tensile stress on the weld area against the support member. Other stress calculations on the supporting member for shear or bending are not performed here, since they would require additional information about the supporting member.

List of variables (Figure 2):

- $A$  = Coupler Diameter
- $B$  = Unfused Diameter
- $R$  = Root Radius of Butt Weld Bevel
- $E$  = Fillet Weld Leg Length on the Supporting Member Side
- $J$  = Fillet Weld Leg Length on the Coupler Side

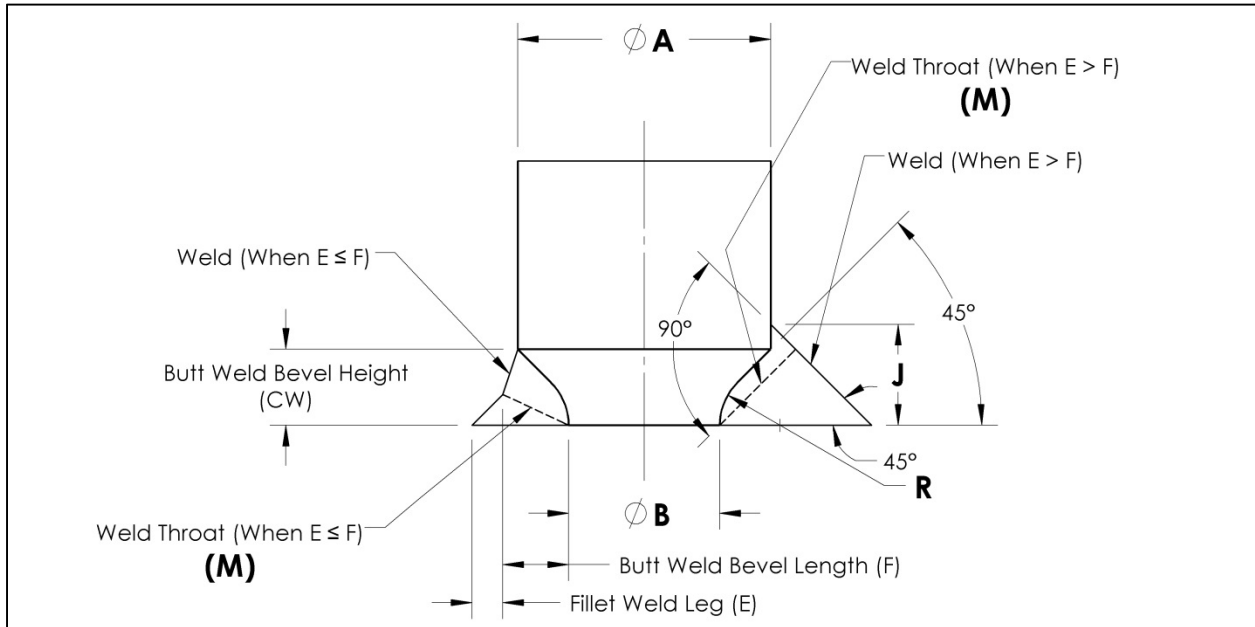

**Figure 2. List of Variables**

Butt weld bevel depth (Figure 3):

$$F = (A - B)/2$$

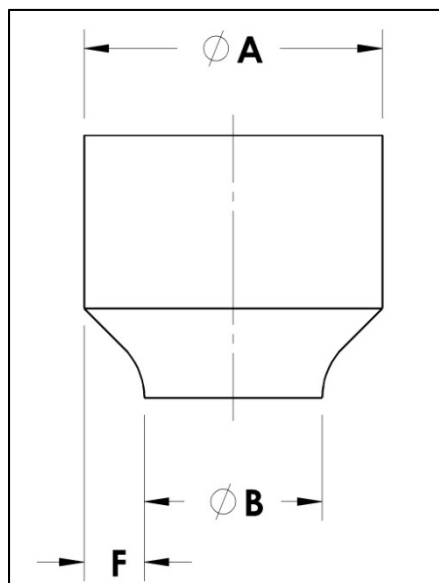

**Figure 3. Butt Weld Bevel Depth**

Butt weld bevel height (Figure 4):

$$C_w = (\sqrt{2}-1) R + F$$

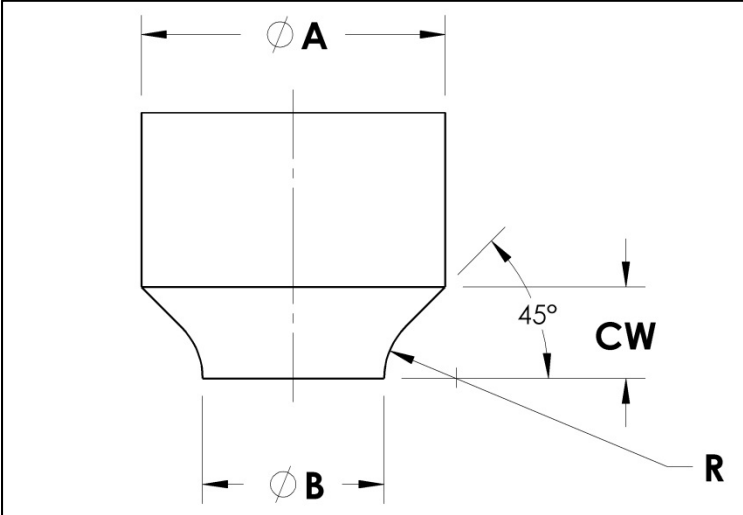

Figure 4. Butt Weld Bevel Height

Weld throat (when  $E \leq F$ ) (Figure 5):

$$M = \sqrt{F^2 + E^2}$$

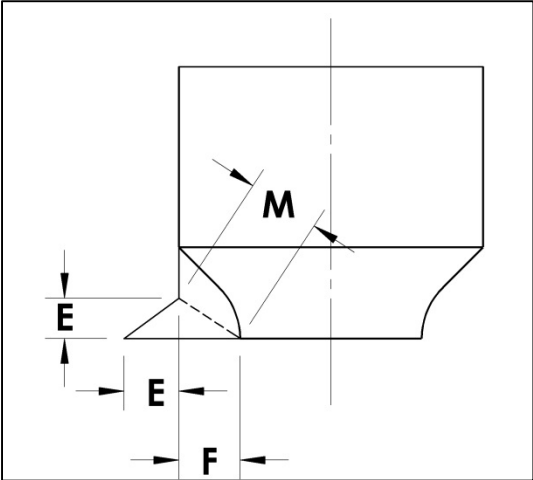
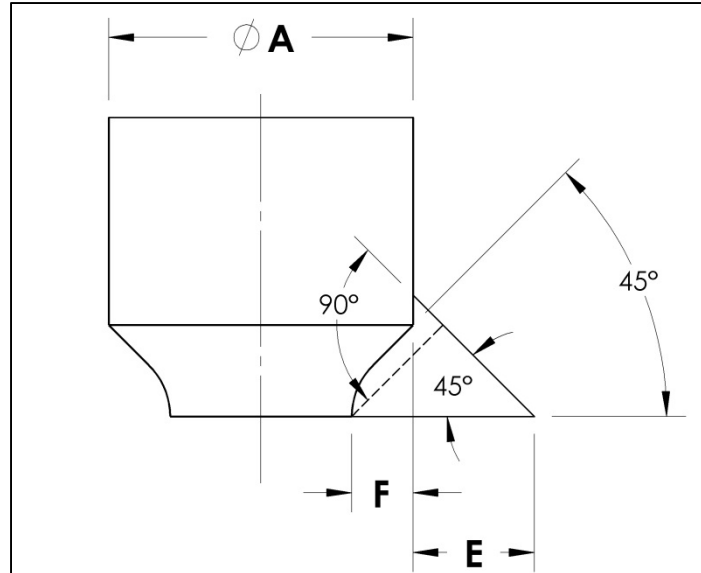

Figure 5. Weld Throat (When  $E \leq F$ )

Weld throat (when  $E > F$ ) (Figure 6):

$$M = (\sqrt{2}/2) (F+E)$$



**Figure 6. Weld Throat (When  $E > F$ )**

Effective weld area (when  $E \leq F$ ) based on the area of the frustum of a cone:

$$W = (\pi/2) M (A + B)$$

Effective weld area (when  $E > F$ ) based on the area of the frustum of a cone:

$$W = (\pi/2) M (2B + F + E)$$

Weld shear stress:

$$\tau_w = F_r / (W\sqrt{2})$$

Shear stress is calculated as the force divided by the area and also divided by a correction factor for the difference in orientation of the force from the rebar and the orientation of the shear at approximately 45 degrees to the rebar axis. Conversion of normal stress to shear stress is described for instance in Roark's Formulas for Stress and Strain by Yong, Budynas, and Sadegh.

Angle of loading to weld axis at all locations (D1.1 Table 2.4):

$$\theta = 90$$

Equivalent strength coefficient (D1.1 Table 2.4):

$$C = 1.5$$

Increased stress in base metal (as allowed by D1.1 2.6.5 and AISC N690 N3.4):

$$\phi = 1.0$$

Alternative allowable weld shear stress by D1.1 2.6.4.4 and 2.6.5:

$$\tau_{wa} = \phi 0.3 \sigma_{Uw} C$$

Some structural codes do not allow the consideration of the effect of weld orientation relative to the loading direction on the strength assessment. **For the case when the code does not allow consideration of the effect of weld orientation relative to the loading direction on strength assessment and  $C = 1.0$ , the weld sizes are given in the Appendix.**

When  $E \leq F$  fillet weld leg length:

$$E = \sqrt{(F_r / ((\pi/2) \tau_{wa} (A + B)))^2 - F^2}$$

Based on:

$$\begin{aligned} \tau_{wa} &= \tau_w \\ \tau_{wa} &= F_r / (\sqrt{2} (\pi/2) M (A+B)) \\ \sqrt{(F^2 + E^2)} &= F_r / (\sqrt{2} (\pi/2) \tau_{wa} (A+B)) \\ E^2 &= (F_r / (\sqrt{2} (\pi/2) \tau_{wa} (A+B)))^2 - F^2 \end{aligned}$$

When  $E > F$  fillet weld leg length:

$$E = -B - F + \sqrt{((B + F)^2 - 2BF + F^2 - Fr / (\pi \tau_{wa}/2))}$$

Based on:

$$\begin{aligned} \tau_{wa} &= \tau_w \\ \tau_{wa} &= F_r / (\sqrt{2} (\pi/2) M (2B + F + E)) \\ \tau_{wa} &= F_r / (\sqrt{2} (\pi/2) (\sqrt{2}/2) (F+E) (2B + F + E)) \\ (F+E) (2B + F + E) &= F_r / (\sqrt{2} (\pi/2) (\sqrt{2}/2) \tau_{wa}) \\ E^2 + (2B+2F)E + (2BF+F^2 - F_r / (\sqrt{2} (\pi/2) (\sqrt{2}/2) \tau_{wa})) &= 0 \\ \text{Solved by quadratic equation } x &= (-b + \sqrt{(b^2 - 4ac)}) / 2a \text{ for } ax^2 + bx + c = 0 \\ \text{Where } a &= 1, b = (2B+2F) \text{ and } c = 2BF+F^2 - F_r / (\sqrt{2} (\pi/2) (\sqrt{2}/2) \tau_{wa} \end{aligned}$$

Length from weld root to weld toe on coupler (when  $C_w > J$ ) (Figure 7):

$$M_c = \sqrt{(F^2 + C_w^2)}$$

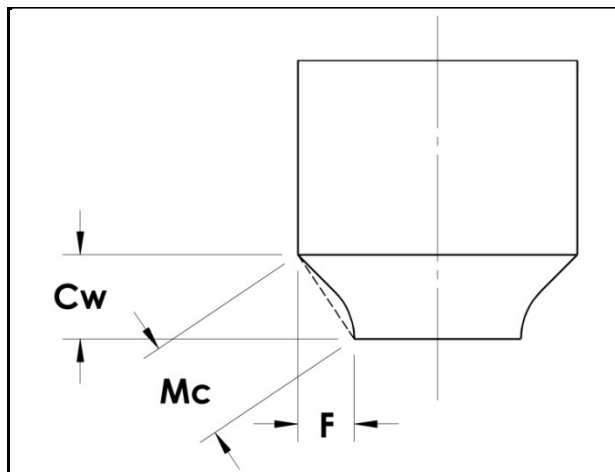
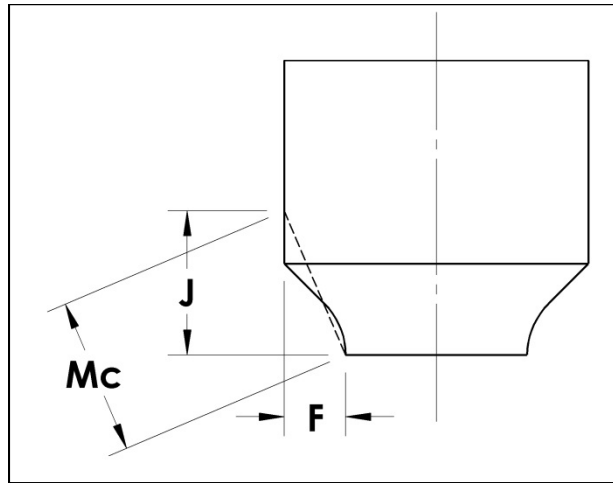

Figure 7. Length from Weld Root to Weld Toe on Coupler (When  $C_w > J$ )



Length from weld root to weld toe on coupler (when  $C_w < J$ ) (Figure 8):

$$M_c = \sqrt{F^2 + J^2}$$



**Figure 8. Length from Weld Root to Weld Toe on Coupler (When  $C_w < J$ )**

Area against coupler based on the area of the frustrum of a cone:

$$A_c = (\pi/2) M_c (A + B)$$

Shear stress on area against coupler:

$$\tau_c = F_r / (A_c \sqrt{2})$$

Shear stress is calculated as the force divided by the area and also divided by a correction factor for the difference in orientation of the force from the rebar and the orientation of the shear at approximately 45 degrees to the rebar axis. Conversion of normal stress to shear stress is described for instance in Roark's Formulas for Stress and Strain by Yong, Budynas, and Sadegh.

Allowable shear stress on area against coupler (D1.1 2.6.5 and Table 2.3):

$$\tau_{ca} = \phi 0.4 \sigma_{yc}$$

Weld area on face of support member based on area of a circular annulus:

$$A_w = (\pi/4) ((A + 2E)^2 - B^2)$$

Stress on face of support member:

$$\sigma_F = F_r / A_w$$

Allowable stress on face of support member (D1.1 2.6.5 and Table 2.3):

$$\sigma_{Fa} = 0.60 \phi \sigma_{yf}$$

Many of the equations use the surface area of a frustum of a cone, as shown in Figure 9.

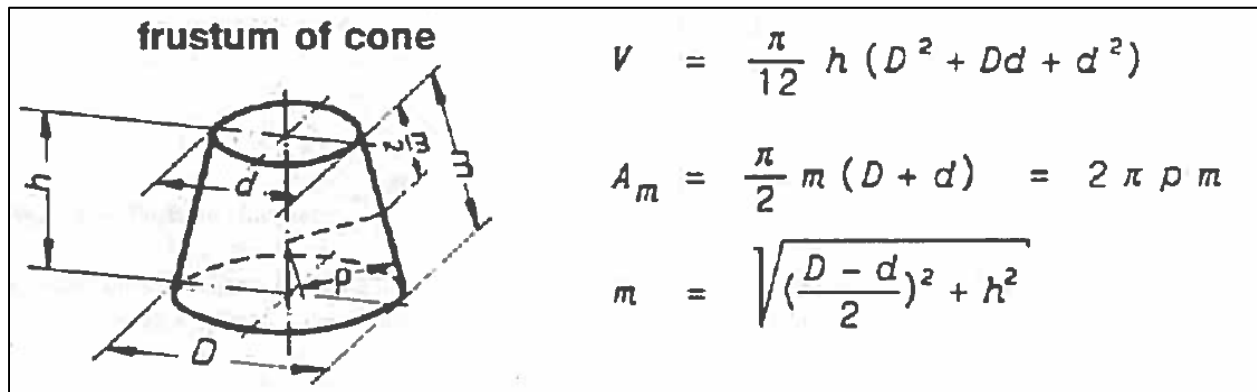

Gieck, Kurt and Gieck, Reiner., Engineering Formulas. 6<sup>th</sup> Edition.

**Figure 9. Surface Area of a Frustum of a Cone**

**C2 and C3J:**

Tables 2 through 5 show the dimensions of the coupler weld area including the minimum leg length of the fillet weld E for forces of Type I and Type II for Grades 60 and 80. These use the minimum yield strength in the coupler of 64 ksi when determining the leg length on the coupler side.

**Table 2. Dimensions for C2 and C3J with ACI318 Type I Forces for ASTM A615 Grade 60 Rebar (Note 1)**

Coupler Family	Part Number	Rebar Size		ØA		ØB		R		E		J	
		in-lbs	Metric	in.	[mm]	in.	[mm]	in.	[mm]	in.	[mm]	in.	[mm]
C2	EL12C2	#4	12	0.75	[19.1]	0.44	[11.2]	0.38	[9.7]	0.092	[2.33]	0.092	[2.33]
	EL14C2		14	1.00	[25.4]	0.56	[14.2]	0.38	[9.7]	0.000	[0.00]	0.000	[0.00]
	EL16C2	#5	16	1.00	[25.4]	0.56	[14.2]	0.38	[9.7]	0.000	[0.00]	0.000	[0.00]
C3J	EL18C3J		18	1.25	[31.8]	0.88	[22.4]	0.38	[9.7]	0.065	[1.66]	0.065	[1.66]
	EL20C3J	#6	20	1.25	[31.8]	0.88	[22.4]	0.38	[9.7]	0.122	[3.09]	0.122	[3.09]
	EL22C3J	#7	22	1.25	[31.8]	0.75	[19.1]	0.38	[9.7]	0.202	[5.14]	0.202	[5.14]
	EL25C3J	#8	25	1.56	[39.7]	1.00	[25.4]	0.38	[9.7]	0.173	[4.41]	0.173	[4.41]
	EL28C3J	#9	28	1.56	[39.7]	0.94	[23.9]	0.38	[9.7]	0.294	[7.47]	0.294	[7.47]
	EL32C3J	#10	32	2.00	[50.8]	0.94	[23.9]	0.38	[9.7]	0.000	[0.00]	0.000	[0.00]
	EL36C3J	#11	36	2.00	[50.8]	1.13	[28.7]	0.38	[9.7]	0.310	[7.88]	0.310	[7.88]
	EL38C3J	#12	38	2.38	[60.3]	1.41	[35.8]	0.38	[9.7]	0.125	[3.17]	0.125	[3.17]
	EL40C3J		40	2.38	[60.3]	1.41	[35.8]	0.38	[9.7]	0.269	[6.82]	0.269	[6.82]
	EL40TC3J		40	2.38	[60.3]	1.41	[35.8]	0.38	[9.7]	0.269	[6.82]	0.269	[6.82]
	EL43TC3J	#14	43	2.38	[60.3]	1.41	[35.8]	0.38	[9.7]	0.416	[10.57]	0.416	[10.57]
	EL50TC3J		50	2.75	[69.4]	1.50	[38.1]	0.38	[9.7]	0.444	[11.28]	0.444	[11.28]
	EL57TC3J	#18	57	3.13	[79.4]	1.75	[44.5]	0.38	[9.7]	0.548	[13.93]	0.548	[13.93]

Note 1: ASTM A615 grade 60 equals the force of ASTM A706 grade 60.

**Table 3. Dimensions for C2 and C3J with ACI 318 Type II Forces for ASTM A615 Grade 60 Rebar (Note 1)**

Coupler Family	Part Number	Rebar Size		ØA		ØB		R		E		J	
		in-lbs	Metric	in.	[mm]	in.	[mm]	in.	[mm]	in.	[mm]	in.	[mm]
C2	EL12C2	#4	12	0.75	[19.1]	0.44	[11.2]	0.38	[9.7]	0.151	[3.83]	0.151	[3.83]
	EL14C2		14	1.00	[25.4]	0.56	[14.2]	0.38	[9.7]	0.000	[0.00]	0.000	[0.00]
	EL16C2	#5	16	1.00	[25.4]	0.56	[14.2]	0.38	[9.7]	0.130	[3.30]	0.130	[3.30]
C3J	EL18C3J		18	1.25	[31.8]	0.88	[22.4]	0.38	[9.7]	0.146	[3.70]	0.146	[3.70]
	EL20C3J	#6	20	1.25	[31.8]	0.88	[22.4]	0.38	[9.7]	0.190	[4.82]	0.190	[4.82]
	EL22C3J	#7	22	1.25	[31.8]	0.75	[19.1]	0.38	[9.7]	0.286	[7.26]	0.286	[7.26]
	EL25C3J	#8	25	1.56	[39.7]	1.00	[25.4]	0.38	[9.7]	0.280	[7.10]	0.280	[7.10]
	EL28C3J	#9	28	1.56	[39.7]	0.94	[23.9]	0.38	[9.7]	0.393	[9.97]	0.551	[13.98]
	EL32C3J	#10	32	2.00	[50.8]	0.94	[23.9]	0.38	[9.7]	0.167	[4.23]	0.167	[4.23]
	EL36C3J	#11	36	2.00	[50.8]	1.13	[28.7]	0.38	[9.7]	0.463	[11.77]	0.658	[16.71]
	EL38C3J	#12	38	2.38	[60.3]	1.41	[35.8]	0.38	[9.7]	0.353	[8.98]	0.353	[8.98]
	EL40C3J		40	2.38	[60.3]	1.41	[35.8]	0.38	[9.7]	0.454	[11.54]	0.657	[16.69]
	EL40TC3J		40	2.38	[60.3]	1.41	[35.8]	0.38	[9.7]	0.454	[11.54]	0.657	[16.69]
	EL43TC3J	#14	43	2.38	[60.3]	1.41	[35.8]	0.38	[9.7]	0.573	[14.56]	0.808	[20.51]
	EL50TC3J		50	2.75	[69.4]	1.50	[38.1]	0.38	[9.7]	0.664	[16.87]	0.944	[23.97]
EL57TC3J	#18	57	3.13	[79.4]	1.75	[44.5]	0.38	[9.7]	0.778	[19.76]	1.102	[27.98]	

Note 1: ASTM A615 grade 60 exceeds the force of ASTM A706 grade 60.

**Table 4. Dimensions for C2 and C3J with ACI318 Type I Forces for ASTM A615 Grade 80 Rebar (Note 1)**

Coupler Family	Part Number	Rebar Size		ØA		ØB		R		E		J	
		in-lbs	Metric	in.	[mm]	in.	[mm]	in.	[mm]	in.	[mm]	in.	[mm]
C2	EL12C2	#4	12	0.75	[19.1]	0.44	[11.2]	0.38	[9.7]	0.178	[4.53]	0.178	[4.53]
	EL14C2		14	1.00	[25.4]	0.56	[14.2]	0.38	[9.7]	0.000	[0.00]	0.000	[0.00]
	EL16C2	#5	16	1.00	[25.4]	0.56	[14.2]	0.38	[9.7]	0.180	[4.56]	0.180	[4.56]
C3J	EL18C3J		18	1.25	[31.8]	0.88	[22.4]	0.38	[9.7]	0.185	[4.70]	0.185	[4.70]
	EL20C3J	#6	20	1.25	[31.8]	0.88	[22.4]	0.38	[9.7]	0.225	[5.71]	0.225	[5.71]
	EL22C3J	#7	22	1.25	[31.8]	0.75	[19.1]	0.38	[9.7]	0.332	[8.44]	0.465	[11.80]
	EL25C3J	#8	25	1.56	[39.7]	1.00	[25.4]	0.38	[9.7]	0.330	[8.39]	0.463	[11.77]
	EL28C3J	#9	28	1.56	[39.7]	0.94	[23.9]	0.38	[9.7]	0.453	[11.51]	0.630	[16.00]
	EL32C3J	#10	32	2.00	[50.8]	0.94	[23.9]	0.38	[9.7]	0.317	[8.04]	0.317	[8.04]
	EL36C3J	#11	36	2.00	[50.8]	1.13	[28.7]	0.38	[9.7]	0.540	[13.71]	0.761	[19.33]
	EL38C3J	#12	38	2.38	[60.3]	1.41	[35.8]	0.38	[9.7]	0.457	[11.61]	0.660	[16.77]
	EL40C3J		40	2.38	[60.3]	1.41	[35.8]	0.38	[9.7]	0.542	[13.78]	0.767	[19.48]
	EL40TC3J		40	2.38	[60.3]	1.41	[35.8]	0.38	[9.7]	0.542	[13.78]	0.767	[19.48]
	EL43TC3J	#14	43	2.38	[60.3]	1.41	[35.8]	0.38	[9.7]	0.664	[16.86]	0.927	[23.55]
	EL50TC3J		50	2.75	[69.4]	1.50	[38.1]	0.38	[9.7]	0.772	[19.61]	1.092	[27.72]
EL57TC3J	#18	57	3.13	[79.4]	1.75	[44.5]	0.38	[9.7]	0.901	[22.89]	1.268	[32.22]	

\*Note 1: ASTM A615 grade 80 exceeds or equals the force of ASTM A615 grade 75 and ASTM A706 grade 80

**Table 5. Dimensions for C2 and C3J with ACI 318 Type II Forces for ASTM A615 Grade 80 Rebar (Note 1)**

Coupler Family	Part Number	Rebar Size		ØA		ØB		R		E		J	
		in-lbs	Metric	in.	[mm]	in.	[mm]	in.	[mm]	in.	[mm]	in.	[mm]
C2	EL12C2	#4	12	0.75	[19.1]	0.44	[11.2]	0.38	[9.7]	0.191	[4.85]	0.191	[4.85]
	EL14C2		14	1.00	[25.4]	0.56	[14.2]	0.38	[9.7]	0.070	[1.78]	0.070	[1.78]
	EL16C2	#5	16	1.00	[25.4]	0.56	[14.2]	0.38	[9.7]	0.201	[5.11]	0.201	[5.11]
C3J	EL18C3J		18	1.25	[31.8]	0.88	[22.4]	0.38	[9.7]	0.201	[5.10]	0.201	[5.10]
	EL20C3J	#6	20	1.25	[31.8]	0.88	[22.4]	0.38	[9.7]	0.242	[6.15]	0.242	[6.15]
	EL22C3J	#7	22	1.25	[31.8]	0.75	[19.1]	0.38	[9.7]	0.355	[9.01]	0.494	[12.55]
	EL25C3J	#8	25	1.56	[39.7]	1.00	[25.4]	0.38	[9.7]	0.355	[9.01]	0.495	[12.57]
	EL28C3J	#9	28	1.56	[39.7]	0.94	[23.9]	0.38	[9.7]	0.482	[12.25]	0.669	[16.99]
	EL32C3J	#10	32	2.00	[50.8]	0.94	[23.9]	0.38	[9.7]	0.373	[9.48]	0.373	[9.48]
	EL36C3J	#11	36	2.00	[50.8]	1.13	[28.7]	0.38	[9.7]	0.577	[14.65]	0.811	[20.60]
	EL38C3J	#12	38	2.38	[60.3]	1.41	[35.8]	0.38	[9.7]	0.500	[12.69]	0.710	[18.04]
	EL40C3J		40	2.38	[60.3]	1.41	[35.8]	0.38	[9.7]	0.583	[14.80]	0.820	[20.82]
	EL40TC3J		40	2.38	[60.3]	1.41	[35.8]	0.38	[9.7]	0.583	[14.80]	0.820	[20.82]
	EL43TC3J	#14	43	2.38	[60.3]	1.41	[35.8]	0.38	[9.7]	0.708	[17.98]	0.998	[25.35]
	EL50TC3J		50	2.75	[69.4]	1.50	[38.1]	0.38	[9.7]	0.825	[20.95]	1.179	[29.94]
EL57TC3J	#18	57	3.13	[79.4]	1.75	[44.5]	0.38	[9.7]	0.961	[24.41]	1.367	[34.73]	

Note 1: ASTM A615 grade 80 exceeds the force of ASTM A615 grade 75 and ASTM A706 grade 80

The shear stress for the adjacent coupler material is acceptable, using the coupler yield strength (64 ksi) and the frustrum cone from the weld root to the weld toe on the coupler.

For all cases the tensile stress on the face of the support member is less than 16 ksi. This will be less than the allowable stress for both A36 steel and for A572 Grade 50. Stresses should also be checked on the structural steel at the outer perimeter of the attachment to make sure that sufficient thickness of structural steel is available to carry the load transmitted as shear and bending stresses.

**P9J:**

Tables 6 through 9 show the dimensions of the coupler weld area including the minimum leg length of the fillet weld E for forces of Type I and Type II for Grades 60 and 80. These use the minimum yield strength in the coupler of 64 ksi when determining the leg length on the coupler side.

**Table 6. Dimensions for P9J with ACI318 Type I Forces for ASTM A615 Grade 60 Rebar (Note 1)**

Coupler Family	Part Number	Rebar Size		ØA		ØB		R		E		J	
		in-lbs	Metric	in.	[mm]	in.	[mm]	in.	[mm]	in.	[mm]	in.	[mm]
P9J(3)	EL20P9J	#6	20	2.00	[50.8]	1.63	[41.3]	0.38	[9.7]	0.000	[0.00]	0.000	[0.00]
	EL22P9J	#7	22	2.00	[50.8]	1.50	[38.1]	0.38	[9.7]	0.000	[0.00]	0.000	[0.00]
	EL25P9J	#8	25	2.00	[50.8]	1.38	[34.9]	0.38	[9.7]	0.000	[0.00]	0.000	[0.00]
	EL28P9J	#9	28	3.00	[76.2]	2.50	[63.5]	0.38	[9.7]	0.000	[0.00]	0.000	[0.00]
	EL32P9J	#10	32	3.00	[76.2]	2.38	[60.3]	0.38	[9.7]	0.000	[0.00]	0.000	[0.00]
	EL36P9J	#11	36	3.00	[76.2]	2.25	[57.2]	0.38	[9.7]	0.000	[0.00]	0.000	[0.00]

Note 1: ASTM A615 grade 60 equals the force of ASTM A706 grade 60.

**Table 7. Dimensions for P9J with ACI 318 Type II Forces for ASTM A615 Grade 60 Rebar (Note 1)**

Coupler Family	Part Number	Rebar Size		ØA		ØB		R		E		J	
		in-lbs	Metric	in.	[mm]	in.	[mm]	in.	[mm]	in.	[mm]	in.	[mm]
P9J(3)	EL20P9J	#6	20	2.00	[50.8]	1.63	[41.3]	0.38	[9.7]	0.000	[0.00]	0.000	[0.00]
	EL22P9J	#7	22	2.00	[50.8]	1.50	[38.1]	0.38	[9.7]	0.000	[0.00]	0.000	[0.00]
	EL25P9J	#8	25	2.00	[50.8]	1.38	[34.9]	0.38	[9.7]	0.000	[0.00]	0.000	[0.00]
	EL28P9J	#9	28	3.00	[76.2]	2.50	[63.5]	0.38	[9.7]	0.000	[0.00]	0.000	[0.00]
	EL32P9J	#10	32	3.00	[76.2]	2.38	[60.3]	0.38	[9.7]	0.000	[0.00]	0.000	[0.00]
	EL36P9J	#11	36	3.00	[76.2]	2.25	[57.2]	0.38	[9.7]	0.074	[1.87]	0.074	[1.87]

Note 1: ASTM A615 grade 60 exceeds the force of ASTM A706 grade 60.

**Table 8. Dimensions for P9J with ACI318 Type I Forces for ASTM A615 Grade 80 Rebar (Note 1\*)**

Coupler Family	Part Number	Rebar Size		ØA		ØB		R		E		J	
		in-lbs	Metric	in.	[mm]	in.	[mm]	in.	[mm]	in.	[mm]	in.	[mm]
P9J(3)	EL20P9J	#6	20	2.00	[50.8]	1.63	[41.3]	0.38	[9.7]	0.000	[0.00]	0.000	[0.00]
	EL22P9J	#7	22	2.00	[50.8]	1.50	[38.1]	0.38	[9.7]	0.000	[0.00]	0.000	[0.00]
	EL25P9J	#8	25	2.00	[50.8]	1.38	[34.9]	0.38	[9.7]	0.119	[3.03]	0.119	[3.03]
	EL28P9J	#9	28	3.00	[76.2]	2.50	[63.5]	0.38	[9.7]	0.071	[1.80]	0.071	[1.80]
	EL32P9J	#10	32	3.00	[76.2]	2.38	[60.3]	0.38	[9.7]	0.128	[3.25]	0.128	[3.25]
	EL36P9J	#11	36	3.00	[76.2]	2.25	[57.2]	0.38	[9.7]	0.199	[5.06]	0.199	[5.06]

\*Note 1: ASTM A615 grade 80 exceeds or equals the force of ASTM A615 grade 75 and ASTM A706 grade 80

**Table 9. Dimensions for P9J with ACI 318 Type II Forces for ASTM A615 Grade 80 Rebar (Note 1)**

Coupler Family	Part Number	Rebar Size		ØA		ØB		R		E		J	
		in-lbs	Metric	in.	[mm]	in.	[mm]	in.	[mm]	in.	[mm]	in.	[mm]
P9J(3)	EL20P9J	#6	20	2.00	[50.8]	1.63	[41.3]	0.38	[9.7]	0.000	[0.00]	0.000	[0.00]
	EL22P9J	#7	22	2.00	[50.8]	1.50	[38.1]	0.38	[9.7]	0.061	[1.54]	0.061	[1.54]
	EL25P9J	#8	25	2.00	[50.8]	1.38	[34.9]	0.38	[9.7]	0.160	[4.07]	0.160	[4.07]
	EL28P9J	#9	28	3.00	[76.2]	2.50	[63.5]	0.38	[9.7]	0.109	[2.77]	0.109	[2.77]
	EL32P9J	#10	32	3.00	[76.2]	2.38	[60.3]	0.38	[9.7]	0.167	[4.25]	0.167	[4.25]
	EL36P9J	#11	36	3.00	[76.2]	2.25	[57.2]	0.38	[9.7]	0.241	[6.13]	0.241	[6.13]

Note 1: ASTM A615 grade 80 exceeds the force of ASTM A615 grade 75 and ASTM A706 grade 80

The shear stress for the adjacent coupler material is acceptable, using the coupler yield strength (64 ksi) and the frustrum cone from the weld root to the weld toe on the coupler.

For all cases the tensile stress on the face of the support member is less than 14 ksi. This will be less than the allowable stress for both A36 steel and for A572 Grade 50. Stresses should also be checked on the structural steel at the outer perimeter of the attachment to make sure that sufficient thickness of structural steel is available to carry the load transmitted as shear and bending stresses.

**CADWELD B:**

Tables 10 through 11 show the dimensions of the coupler weld area including the minimum leg length of the fillet weld E for forces of Type I and Type II for Grades 60 and 80. These use the minimum yield strength in the coupler of 64 ksi when determining the leg length on the coupler side.

**Table 10. Dimensions for CADWELD B with ACI318 Type I Forces for ASTM A615 Grade 60 Rebar (Note 1)**

Coupler Family	Part Number	Rebar Size		ØA		ØB		R		E		J	
		in-lbs	Metric	in.	[mm]	in.	[mm]	in.	[mm]	in.	[mm]	in.	[mm]
Cad weld Sleeve RBB xxxJA	RBB592JA	#4	12	1.38	[34.9]	1.04	[26.3]	0.38	[9.7]	0.000	[0.00]	0.000	[0.00]
	RBB592JA	#5	16	1.38	[34.9]	1.04	[26.3]	0.38	[9.7]	0.000	[0.00]	0.000	[0.00]
	RBB692JA	#6	20	1.50	[38.1]	1.16	[29.5]	0.38	[9.7]	0.050	[1.28]	0.050	[1.28]
	RBB792JA	#7	22	1.63	[41.3]	1.29	[32.6]	0.38	[9.7]	0.141	[3.59]	0.141	[3.59]
	RBB8101JA	#8	25	1.88	[47.6]	1.42	[36.0]	0.38	[9.7]	0.118	[2.98]	0.118	[2.98]
	RBB992JA	#9	28	2.13	[54.0]	1.67	[42.4]	0.38	[9.7]	0.166	[4.22]	0.166	[4.22]
	RBB1092JA	#10	32	2.25	[57.2]	1.79	[45.5]	0.38	[9.7]	0.245	[6.24]	0.245	[6.24]
	RBB11101JA	#11	36	2.50	[63.5]	1.93	[48.9]	0.38	[9.7]	0.245	[6.23]	0.245	[6.23]
	RBB14101JA	#14	43	3.00	[76.2]	2.31	[58.6]	0.38	[9.7]	0.294	[7.47]	0.294	[7.47]
RBB1892JA	#18	57	3.75	[95.3]	2.83	[71.8]	0.38	[9.7]	0.460	[11.67]	0.640	[16.27]	

Note 1: ASTM A615 grade 60 equals the force of ASTM A706 grade 60.

**Table 11. Dimensions for CADWELD B with ACI 318 Type II Forces for ASTM A615 Grade 60 Rebar (Note 1)**

Coupler Family	Part Number	Rebar Size		ØA		ØB		R		E		J	
		in-lbs	Metric	in.	[mm]	in.	[mm]	in.	[mm]	in.	[mm]	in.	[mm]
Cad weld Sleeve RBB xxxJA	RBB592JA	#4	12	1.38	[34.9]	1.04	[26.3]	0.38	[9.7]	0.000	[0.00]	0.000	[0.00]
	RBB592JA	#5	16	1.38	[34.9]	1.04	[26.3]	0.38	[9.7]	0.000	[0.00]	0.000	[0.00]
	RBB692JA	#6	20	1.50	[38.1]	1.16	[29.5]	0.38	[9.7]	0.128	[3.25]	0.128	[3.25]
	RBB792JA	#7	22	1.63	[41.3]	1.29	[32.6]	0.38	[9.7]	0.201	[5.11]	0.201	[5.11]
	RBB8101JA	#8	25	1.88	[47.6]	1.42	[36.0]	0.38	[9.7]	0.207	[5.26]	0.207	[5.26]
	RBB992JA	#9	28	2.13	[54.0]	1.67	[42.4]	0.38	[9.7]	0.248	[6.31]	0.248	[6.31]
	RBB1092JA	#10	32	2.25	[57.2]	1.79	[45.5]	0.38	[9.7]	0.329	[8.35]	0.441	[11.21]
	RBB11101JA	#11	36	2.50	[63.5]	1.93	[48.9]	0.38	[9.7]	0.345	[8.77]	0.478	[12.15]
	RBB14101JA	#14	43	3.00	[76.2]	2.31	[58.6]	0.38	[9.7]	0.415	[10.54]	0.575	[14.60]
RBB1892JA	#18	57	3.75	[95.3]	2.83	[71.8]	0.38	[9.7]	0.618	[15.71]	0.844	[21.45]	

Note 1: ASTM A615 grade 60 exceeds the force of ASTM A706 grade 60.

The shear stress for the adjacent coupler material is acceptable, using the coupler yield strength (64 ksi) and the frustrum cone from the weld root to the weld toe on the coupler.

For all cases the tensile stress on the face of the support member is less than 16 ksi. This will be less than the allowable stress for both A36 steel and for A572 Grade 50. Stresses should also be checked on the structural steel at the outer perimeter of the attachment to make sure that sufficient thickness of structural steel is available to carry the load transmitted as shear and bending stresses.

**C13:**

Tables 12 through 15 show the dimensions of the coupler weld area including the minimum leg length of the fillet weld E for forces of Type I and Type II for Grades 60 and 80. These use the minimum yield strength in the coupler of 64 ksi when determining the leg length on the coupler side.

**Table 12. Dimensions for C13 with ACI318 Type I Forces for ASTM A615 Grade 60 Rebar (Note 1)**

Coupler Family	Part Number	Rebar Size		ØA		ØB		R		E		J	
		in-lbs	Metric	in.	[mm]	in.	[mm]	in.	[mm]	in.	[mm]	in.	[mm]
C13	EL12C13	#4	12	0.75	[19.1]	0.44	[11.2]	0.39	[10.0]	0.092	[2.33]	0.092	[2.33]
	EL14C13	-	14	1.00	[25.4]	0.69	[17.5]	0.39	[10.0]	0.000	[0.00]	0.000	[0.00]
	EL16C13	#5	16	1.00	[25.4]	0.69	[17.5]	0.39	[10.0]	0.121	[3.07]	0.121	[3.07]
	EL18C13	-	18	1.25	[31.8]	0.94	[23.9]	0.39	[10.0]	0.111	[2.83]	0.111	[2.83]
	EL20C13	#6	20	1.25	[31.8]	0.88	[22.4]	0.39	[10.0]	0.122	[3.09]	0.122	[3.09]
	EL22C13	#7	22	1.25	[31.8]	0.63	[16.0]	0.39	[10.0]	0.145	[3.67]	0.145	[3.67]
	EL25C13	#8	25	1.56	[39.6]	0.94	[23.9]	0.39	[10.0]	0.136	[3.47]	0.136	[3.47]
	EL28C13	#9	28	1.56	[39.6]	0.63	[16.0]	0.39	[10.0]	0.153	[3.88]	0.153	[3.88]
	EL32C13	#10	32	2.00	[50.8]	1.25	[31.8]	0.39	[10.0]	0.187	[4.74]	0.187	[4.74]
	EL36C13	#11	36	2.00	[50.8]	0.88	[22.4]	0.39	[10.0]	0.153	[3.89]	0.153	[3.89]
	EL38C13	-	38	2.38	[60.5]	1.50	[38.1]	0.39	[10.0]	0.207	[5.25]	0.207	[5.25]
	EL40C13	-	40	2.38	[60.5]	1.25	[31.8]	0.39	[10.0]	0.111	[2.81]	0.111	[2.81]
	EL40TC13	-	40	2.38	[60.5]	1.41	[35.8]	0.39	[10.0]	0.262	[6.65]	0.262	[6.65]
	EL43TC13	#14	43	2.38	[60.5]	1.00	[25.4]	0.39	[10.0]	0.182	[4.61]	0.182	[4.61]
	EL50TC13	-	50	2.75	[69.9]	1.13	[28.7]	0.39	[10.0]	0.222	[5.63]	0.222	[5.63]
EL57TC13	#18	57	3.13	[79.5]	1.25	[31.8]	0.39	[10.0]	0.273	[6.93]	0.273	[6.93]	

Note 1: ASTM A615 grade 60 equals the force of ASTM A706 grade 60.

**Table 13. Dimensions for C13 with ACI 318 Type II Forces for ASTM A615 Grade 60 Rebar (Note 1)**

Coupler Family	Part Number	Rebar Size		ØA		ØB		R		E		J	
		in-lbs	Metric	in.	[mm]	in.	[mm]	in.	[mm]	in.	[mm]	in.	[mm]
C13	EL12C13	#4	12	0.75	[19.1]	0.44	[11.2]	0.39	[10.0]	0.151	[3.83]	0.151	[3.83]
	EL14C13	-	14	1.00	[25.4]	0.69	[17.5]	0.39	[10.0]	0.097	[2.45]	0.097	[2.45]
	EL16C13	#5	16	1.00	[25.4]	0.69	[17.5]	0.39	[10.0]	0.175	[4.44]	0.175	[4.44]
	EL18C13	-	18	1.25	[31.8]	0.94	[23.9]	0.39	[10.0]	0.167	[4.25]	0.167	[4.25]
	EL20C13	#6	20	1.25	[31.8]	0.88	[22.4]	0.39	[10.0]	0.190	[4.82]	0.190	[4.82]
	EL22C13	#7	22	1.25	[31.8]	0.63	[16.0]	0.39	[10.0]	0.269	[6.83]	0.269	[6.83]
	EL25C13	#8	25	1.56	[39.6]	0.94	[23.9]	0.39	[10.0]	0.263	[6.68]	0.263	[6.68]
	EL28C13	#9	28	1.56	[39.6]	0.63	[16.0]	0.39	[10.0]	0.359	[9.11]	0.359	[9.11]
	EL32C13	#10	32	2.00	[50.8]	1.25	[31.8]	0.39	[10.0]	0.335	[8.50]	0.335	[8.50]
	EL36C13	#11	36	2.00	[50.8]	0.88	[22.4]	0.39	[10.0]	0.414	[10.53]	0.414	[10.53]
	EL38C13	-	38	2.38	[60.5]	1.50	[38.1]	0.39	[10.0]	0.383	[9.73]	0.383	[9.73]
	EL40C13	-	40	2.38	[60.5]	1.25	[31.8]	0.39	[10.0]	0.398	[10.10]	0.398	[10.10]
	EL40TC13	-	40	2.38	[60.5]	1.41	[35.8]	0.39	[10.0]	0.450	[11.43]	0.654	[16.61]
	EL43TC13	#14	43	2.38	[60.5]	1.00	[25.4]	0.39	[10.0]	0.507	[12.88]	0.507	[12.88]
	EL50TC13	-	50	2.75	[69.9]	1.13	[28.7]	0.39	[10.0]	0.599	[15.23]	0.599	[15.23]
EL57TC13	#18	57	3.13	[79.5]	1.25	[31.8]	0.39	[10.0]	0.704	[17.89]	0.704	[17.89]	

Note 1: ASTM A615 grade 60 exceeds the force of ASTM A706 grade 60.

**Table 14. Dimensions for C13 with ACI318 Type I Forces for ASTM A615 Grade 80 Rebar (Note 1)**

Coupler Family	Part Number	Rebar Size		ØA		ØB		R		E		J	
		in-lbs	Metric	in.	[mm]	in.	[mm]	in.	[mm]	in.	[mm]	in.	[mm]
C13	EL12C13	#4	12	0.75	[19.1]	0.44	[11.2]	0.39	[10.0]	0.178	[4.53]	0.178	[4.53]
	EL14C13	-	14	1.00	[25.4]	0.69	[17.5]	0.39	[10.0]	0.131	[3.33]	0.131	[3.33]
	EL16C13	#5	16	1.00	[25.4]	0.69	[17.5]	0.39	[10.0]	0.205	[5.21]	0.205	[5.21]
	EL18C13	-	18	1.25	[31.8]	0.94	[23.9]	0.39	[10.0]	0.198	[5.03]	0.198	[5.03]
	EL20C13	#6	20	1.25	[31.8]	0.88	[22.4]	0.39	[10.0]	0.225	[5.71]	0.225	[5.71]
	EL22C13	#7	22	1.25	[31.8]	0.63	[16.0]	0.39	[10.0]	0.329	[8.35]	0.329	[8.35]
	EL25C13	#8	25	1.56	[39.6]	0.94	[23.9]	0.39	[10.0]	0.325	[8.25]	0.325	[8.25]
	EL28C13	#9	28	1.56	[39.6]	0.63	[16.0]	0.39	[10.0]	0.458	[11.63]	0.655	[16.63]
	EL32C13	#10	32	2.00	[50.8]	1.25	[31.8]	0.39	[10.0]	0.407	[10.34]	0.576	[14.63]
	EL36C13	#11	36	2.00	[50.8]	0.88	[22.4]	0.39	[10.0]	0.534	[13.57]	0.770	[19.57]
	EL38C13	-	38	2.38	[60.5]	1.50	[38.1]	0.39	[10.0]	0.470	[11.93]	0.665	[16.90]
	EL40C13	-	40	2.38	[60.5]	1.25	[31.8]	0.39	[10.0]	0.520	[13.20]	0.757	[19.23]
	EL40TC13	-	40	2.38	[60.5]	1.41	[35.8]	0.39	[10.0]	0.540	[13.71]	0.764	[19.40]
	EL43TC13	#14	43	2.38	[60.5]	1.00	[25.4]	0.39	[10.0]	0.655	[16.63]	0.946	[24.02]
	EL50TC13	-	50	2.75	[69.9]	1.13	[28.7]	0.39	[10.0]	0.773	[19.64]	1.114	[28.31]
EL57TC13	#18	57	3.13	[79.5]	1.25	[31.8]	0.39	[10.0]	0.905	[23.00]	1.302	[33.07]	

Note 1: ASTM A615 grade 80 exceeds or equals the force of ASTM A615 grade 75 and ASTM A706 grade 80

**Table 15. Dimensions for C13 with ACI 318 Type II Forces for ASTM A615 Grade 80 Rebar (Note 1)**

Coupler Family	Part Number	Rebar Size		ØA		ØB		R		E		J	
		in-lbs	Metric	in.	[mm]	in.	[mm]	in.	[mm]	in.	[mm]	in.	[mm]
C13	EL12C13	#4	12	0.75	[19.1]	0.44	[11.2]	0.39	[10.0]	0.191	[4.85]	0.191	[4.85]
	EL14C13	-	14	1.00	[25.4]	0.69	[17.5]	0.39	[10.0]	0.146	[3.71]	0.146	[3.71]
	EL16C13	#5	16	1.00	[25.4]	0.69	[17.5]	0.39	[10.0]	0.220	[5.58]	0.220	[5.58]
	EL18C13	-	18	1.25	[31.8]	0.94	[23.9]	0.39	[10.0]	0.213	[5.41]	0.213	[5.41]
	EL20C13	#6	20	1.25	[31.8]	0.88	[22.4]	0.39	[10.0]	0.242	[6.15]	0.242	[6.15]
	EL22C13	#7	22	1.25	[31.8]	0.63	[16.0]	0.39	[10.0]	0.352	[8.95]	0.501	[12.73]
	EL25C13	#8	25	1.56	[39.6]	0.94	[23.9]	0.39	[10.0]	0.350	[8.89]	0.494	[12.55]
	EL28C13	#9	28	1.56	[39.6]	0.63	[16.0]	0.39	[10.0]	0.492	[12.50]	0.703	[17.86]
	EL32C13	#10	32	2.00	[50.8]	1.25	[31.8]	0.39	[10.0]	0.438	[11.13]	0.616	[15.66]
	EL36C13	#11	36	2.00	[50.8]	0.88	[22.4]	0.39	[10.0]	0.501	[12.73]	0.709	[18.01]
	EL38C13	-	38	2.38	[60.5]	1.50	[38.1]	0.39	[10.0]	0.581	[14.76]	0.829	[21.05]
	EL40C13	-	40	2.38	[60.5]	1.25	[31.8]	0.39	[10.0]	0.506	[12.86]	0.713	[18.10]
	EL40TC13	-	40	2.38	[60.5]	1.41	[35.8]	0.39	[10.0]	0.573	[14.54]	0.815	[20.71]
	EL43TC13	#14	43	2.38	[60.5]	1.00	[25.4]	0.39	[10.0]	0.580	[14.73]	0.817	[20.75]
	EL50TC13	-	50	2.75	[69.9]	1.13	[28.7]	0.39	[10.0]	0.713	[18.11]	1.017	[25.83]
EL57TC13	#18	57	3.13	[79.5]	1.25	[31.8]	0.39	[10.0]	0.840	[21.33]	1.199	[30.44]	

Note 1: ASTM A615 grade 80 exceeds the force of ASTM A615 grade 75 and ASTM A706 grade 80

The shear stress for the adjacent coupler material is acceptable, using the coupler yield strength (64 ksi) and the frustrum cone from the weld root to the weld toe on the coupler.

For all cases the tensile stress on the face of the support member is less than 16 ksi. This will be less than the allowable stress for both A36 steel and for A572 Grade 50. Stresses should also be checked on the structural steel at the outer perimeter of the attachment to make sure that sufficient thickness of structural steel is available to carry the load transmitted as shear and bending stresses.



**C14:**

Tables 16 through 19 show the dimensions of the coupler weld area including the minimum leg length of the fillet weld E for forces of Type I and Type II for Grades 60 and 80. These use the minimum yield strength in the coupler of 50.8 ksi for sizes from EL10C14 to EL18C14 of 50.0 ksi for sizes from EL18C14 to EL32C14 and 47.1 ksi for sizes from EL34C14 to EL57C14 when determining the leg length on the coupler side.

**Table 16. Dimensions for C14 with ACI318 Type I Forces for ASTM A615 Grade 60 Rebar (Note 1)**

Coupler Family	Part Number	Rebar Size		ØA		ØB		R		E		J	
		in-lbs	Metric	in.	[mm]	in.	[mm]	in.	[mm]	in.	[mm]	in.	[mm]
C14	EL10C14	#3	10	1.00	[25.4]	0.69	[17.5]	0.35	[9.0]	0.000	[0.00]	0.000	[0.00]
	EL12C14	#4	12	1.25	[31.8]	0.94	[23.9]	0.35	[9.0]	0.000	[0.00]	0.000	[0.00]
	EL14C14	-	14	1.25	[31.8]	0.88	[22.4]	0.35	[9.0]	0.000	[0.00]	0.000	[0.00]
	EL16C14	#5	16	1.50	[38.1]	1.19	[30.2]	0.35	[9.0]	0.000	[0.00]	0.000	[0.00]
	EL18C14	-	18	1.50	[38.1]	1.13	[28.7]	0.35	[9.0]	0.000	[0.00]	0.000	[0.00]
	EL20C14	#6	20	1.75	[44.5]	1.38	[35.1]	0.35	[9.0]	0.000	[0.00]	0.000	[0.00]
	EL22C14	#7	22	1.75	[44.5]	1.25	[31.8]	0.35	[9.0]	0.000	[0.00]	0.000	[0.00]
	EL25C14	#8	25	2.00	[50.8]	1.44	[36.6]	0.35	[9.0]	0.000	[0.00]	0.000	[0.00]
	EL28C14	#9	28	2.25	[57.2]	1.63	[41.4]	0.35	[9.0]	0.000	[0.00]	0.000	[0.00]
	EL30C14	-	30	2.50	[63.5]	1.88	[47.8]	0.35	[9.0]	0.000	[0.00]	0.000	[0.00]
	EL32C14	#10	32	2.50	[63.5]	1.75	[44.5]	0.35	[9.0]	0.000	[0.00]	0.000	[0.00]
	EL34C14	-	34	2.50	[63.5]	1.75	[44.5]	0.35	[9.0]	0.000	[0.00]	0.000	[0.00]
	EL36C14	#11	36	2.50	[63.5]	1.63	[41.4]	0.35	[9.0]	0.000	[0.00]	0.000	[0.00]
	EL38C14	-	38	3.00	[76.2]	2.25	[57.2]	0.35	[9.0]	0.000	[0.00]	0.000	[0.00]
	EL40C14	-	40	3.00	[76.2]	2.13	[54.1]	0.35	[9.0]	0.000	[0.00]	0.000	[0.00]
	EL43TC14	#14	43	3.25	[82.6]	2.25	[57.2]	0.35	[9.0]	0.000	[0.00]	0.000	[0.00]
	EL50TC14	-	50	3.75	[95.3]	2.63	[66.7]	0.35	[9.0]	0.000	[0.00]	0.000	[0.00]
EL57TC14	#18	57	4.00	[101.6]	2.63	[66.8]	0.35	[9.0]	0.500	[12.70]	0.835	[21.22]	

Note 1: ASTM A615 grade 60 equals the force of ASTM A706 grade 60.

**Table 17. Dimensions for C14 with ACI 318 Type II Forces for ASTM A615 Grade 60 Rebar (Note 1)**

Coupler Family	Part Number	Rebar Size		ØA		ØB		R		E		J	
		in-lbs	Metric	in.	[mm]	in.	[mm]	in.	[mm]	in.	[mm]	in.	[mm]
C14	EL10C14	#3	10	1.00	[25.4]	0.69	[17.5]	0.35	[9.0]	0.000	[0.00]	0.000	[0.00]
	EL12C14	#4	12	1.25	[31.8]	0.94	[23.9]	0.35	[9.0]	0.000	[0.00]	0.000	[0.00]
	EL14C14	-	14	1.25	[31.8]	0.88	[22.4]	0.35	[9.0]	0.000	[0.00]	0.000	[0.00]
	EL16C14	#5	16	1.50	[38.1]	1.19	[30.2]	0.35	[9.0]	0.000	[0.00]	0.000	[0.00]
	EL18C14	-	18	1.50	[38.1]	1.13	[28.7]	0.35	[9.0]	0.046	[1.18]	0.046	[1.18]
	EL20C14	#6	20	1.75	[44.5]	1.38	[35.1]	0.35	[9.0]	0.000	[0.00]	0.000	[0.00]
	EL22C14	#7	22	1.75	[44.5]	1.25	[31.8]	0.35	[9.0]	0.061	[1.54]	0.061	[1.54]
	EL25C14	#8	25	2.00	[50.8]	1.44	[36.6]	0.35	[9.0]	0.094	[2.39]	0.094	[2.39]
	EL28C14	#9	28	2.25	[57.2]	1.63	[41.4]	0.35	[9.0]	0.117	[2.98]	0.117	[2.98]
	EL30C14	-	30	2.50	[63.5]	1.88	[47.8]	0.35	[9.0]	0.091	[2.31]	0.091	[2.31]
	EL32C14	#10	32	2.50	[63.5]	1.75	[44.5]	0.35	[9.0]	0.084	[2.14]	0.084	[2.14]
	EL34C14	-	34	2.50	[63.5]	1.75	[44.5]	0.35	[9.0]	0.250	[6.35]	0.606	[15.40]
	EL36C14	#11	36	2.50	[63.5]	1.63	[41.4]	0.35	[9.0]	0.250	[6.35]	0.685	[17.40]
	EL38C14	-	38	3.00	[76.2]	2.25	[57.2]	0.35	[9.0]	0.250	[6.35]	0.615	[15.62]
	EL40C14	-	40	3.00	[76.2]	2.13	[54.1]	0.35	[9.0]	0.250	[6.35]	0.691	[17.56]
	EL43TC14	#14	43	3.25	[82.6]	2.25	[57.2]	0.35	[9.0]	0.250	[6.35]	0.723	[18.36]
	EL50TC14	-	50	3.75	[95.3]	2.63	[66.7]	0.35	[9.0]	0.500	[12.70]	0.856	[21.75]
EL57TC14	#18	57	4.00	[101.6]	2.63	[66.8]	0.35	[9.0]	0.500	[12.70]	1.101	[27.96]	

Note 1: ASTM A615 grade 60 exceeds the force of ASTM A706 grade 60.

**Table 18. Dimensions for C14 with ACI318 Type I Forces for ASTM A615 Grade 80 Rebar (Note 1)**

Coupler Family	Part Number	Rebar Size		ØA		ØB		R		E		J	
		in-lbs	Metric	in.	[mm]	in.	[mm]	in.	[mm]	in.	[mm]	in.	[mm]
C14	EL10C14	#3	10	1.00	[25.4]	0.69	[17.5]	0.35	[9.0]	0.000	[0.00]	0.000	[0.00]
	EL12C14	#4	12	1.25	[31.8]	0.94	[23.9]	0.35	[9.0]	0.000	[0.00]	0.000	[0.00]
	EL14C14	-	14	1.25	[31.8]	0.88	[22.4]	0.35	[9.0]	0.000	[0.00]	0.000	[0.00]
	EL16C14	#5	16	1.50	[38.1]	1.19	[30.2]	0.35	[9.0]	0.056	[1.41]	0.056	[1.41]
	EL18C14	-	18	1.50	[38.1]	1.13	[28.7]	0.35	[9.0]	0.103	[2.63]	0.103	[2.63]
	EL20C14	#6	20	1.75	[44.5]	1.38	[35.1]	0.35	[9.0]	0.078	[1.99]	0.078	[1.99]
	EL22C14	#7	22	1.75	[44.5]	1.25	[31.8]	0.35	[9.0]	0.139	[3.52]	0.139	[3.52]
	EL25C14	#8	25	2.00	[50.8]	1.44	[36.6]	0.35	[9.0]	0.250	[6.35]	0.434	[11.02]
	EL28C14	#9	28	2.25	[57.2]	1.63	[41.4]	0.35	[9.0]	0.250	[6.35]	0.490	[12.44]
	EL30C14	-	30	2.50	[63.5]	1.88	[47.8]	0.35	[9.0]	0.250	[6.35]	0.472	[11.99]
	EL32C14	#10	32	2.50	[63.5]	1.75	[44.5]	0.35	[9.0]	0.250	[6.35]	0.558	[14.17]
	EL34C14	-	34	2.50	[63.5]	1.75	[44.5]	0.35	[9.0]	0.290	[7.37]	0.698	[17.72]
	EL36C14	#11	36	2.50	[63.5]	1.63	[41.4]	0.35	[9.0]	0.500	[12.70]	0.790	[20.07]
	EL38C14	-	38	3.00	[76.2]	2.25	[57.2]	0.35	[9.0]	0.298	[7.57]	0.707	[17.96]
	EL40C14	-	40	3.00	[76.2]	2.13	[54.1]	0.35	[9.0]	0.500	[12.70]	0.796	[20.23]
	EL43TC14	#14	43	3.25	[82.6]	2.25	[57.2]	0.35	[9.0]	0.500	[12.70]	0.839	[21.31]
EL50TC14	-	50	3.75	[95.3]	2.63	[66.7]	0.35	[9.0]	0.500	[12.70]	0.990	[25.14]	
EL57TC14	#18	57	4.00	[101.6]	2.63	[66.8]	0.35	[9.0]	0.524	[13.30]	1.267	[32.18]	

Note 1: ASTM A615 grade 80 exceeds or equals the force of ASTM A615 grade 75 and ASTM A706 grade 80

**Table 19. Dimensions for C14 with ACI 318 Type II Forces for ASTM A615 Grade 80 Rebar (Note 1)**

Coupler Family	Part Number	Rebar Size		ØA		ØB		R		E		J	
		in-lbs	Metric	in.	[mm]	in.	[mm]	in.	[mm]	in.	[mm]	in.	[mm]
C14	EL10C14	#3	10	1.00	[25.4]	0.69	[17.5]	0.35	[9.0]	0.000	[0.00]	0.000	[0.00]
	EL12C14	#4	12	1.25	[31.8]	0.94	[23.9]	0.35	[9.0]	0.000	[0.00]	0.000	[0.00]
	EL14C14	-	14	1.25	[31.8]	0.88	[22.4]	0.35	[9.0]	0.000	[0.00]	0.000	[0.00]
	EL16C14	#5	16	1.50	[38.1]	1.19	[30.2]	0.35	[9.0]	0.077	[1.95]	0.077	[1.95]
	EL18C14	-	18	1.50	[38.1]	1.13	[28.7]	0.35	[9.0]	0.124	[3.14]	0.124	[3.14]
	EL20C14	#6	20	1.75	[44.5]	1.38	[35.1]	0.35	[9.0]	0.101	[2.57]	0.101	[2.57]
	EL22C14	#7	22	1.75	[44.5]	1.25	[31.8]	0.35	[9.0]	0.250	[6.35]	0.401	[10.18]
	EL25C14	#8	25	2.00	[50.8]	1.44	[36.6]	0.35	[9.0]	0.250	[6.35]	0.464	[11.80]
	EL28C14	#9	28	2.25	[57.2]	1.63	[41.4]	0.35	[9.0]	0.250	[6.35]	0.524	[13.30]
	EL30C14	-	30	2.50	[63.5]	1.88	[47.8]	0.35	[9.0]	0.250	[6.35]	0.506	[12.84]
	EL32C14	#10	32	2.50	[63.5]	1.75	[44.5]	0.35	[9.0]	0.250	[6.35]	0.598	[15.18]
	EL34C14	-	34	2.50	[63.5]	1.75	[44.5]	0.35	[9.0]	0.327	[8.32]	0.742	[18.86]
	EL36C14	#11	36	2.50	[63.5]	1.63	[41.4]	0.35	[9.0]	0.500	[12.70]	0.841	[21.36]
	EL38C14	-	38	3.00	[76.2]	2.25	[57.2]	0.35	[9.0]	0.500	[12.70]	0.752	[19.10]
	EL40C14	-	40	3.00	[76.2]	2.13	[54.1]	0.35	[9.0]	0.500	[12.70]	0.848	[21.53]
	EL43TC14	#14	43	3.25	[82.6]	2.25	[57.2]	0.35	[9.0]	0.500	[12.70]	0.895	[22.74]
EL50TC14	-	50	3.75	[95.3]	2.63	[66.7]	0.35	[9.0]	0.500	[12.70]	1.055	[26.79]	
EL57TC14	#18	57	4.00	[101.6]	2.63	[66.8]	0.35	[9.0]	0.592	[15.03]	1.348	[34.25]	

Note 1: ASTM A615 grade 80 exceeds the force of ASTM A615 grade 75 and ASTM A706 grade 80

The weld sizes for C14 couplers are set by the requirement for the fillet height along the coupler size. Where fillets are required, a minimum value of *E* of 0.25 in. has been chosen, so that the fillets can be effectively tapered onto the supporting member. This is increased to 0.50 in. when the leg on the coupler exceeds 0.75 in. so that the ratio of the fillet legs *J* and *E* does not exceed 3.

For all cases the tensile stress on the face of the support member is less than 15 ksi. This will be less than the allowable stress for both A36 steel and for A572 Grade 50. Stresses should also be checked on the structural steel at the outer perimeter of the attachment to make sure that sufficient thickness of structural steel is available to carry the load transmitted as shear and bending stresses.

**Conclusions and Recommendations:** The results calculated by the AWS D1.1 method indicate weld sizes for the cases of interest.

The weld sizes reported in the tables can be reduced by increasing the weld metal strength. This can be checked by using the equations provided in the report.

It is expected that the weld sizes from these calculations will be conservative compared to those required by testing to avoid failures in the weld or the adjacent structural steel.

**Disclaimer:** EWI disclaims all warranties, express or implied, including, without limitation, any implied warranty of merchantability or fitness for a particular purpose.

Under no circumstances will EWI be liable for incidental or consequential damages, or for any other loss, damage, or expense, arising out of or in connection with the use of or inability to use the report delivered under this engagement. This report may not be reproduced or disseminated to individuals or entities outside of your organization without the prior written approval of EWI.

**For more information contact:** William Mohr at 614.688.5182

#### **Appendix:**

For cases where the structural code does not allow for the inclusion of effects of the orientation of the weld compared to the loading direction, the fillet size calculation results require larger weld sizes than those calculated in the main text. Examples of such structural codes are older versions than AISC 360:2016 Specification for Design, Fabrication, and Erection of Structural Steel for Buildings and AISC N690:2015 Specification for Safety-Related Steel Structures for Nuclear Facilities.

#### **C2 and C3J:**

Tables Appendix1 through Appendix4 show the dimensions of the coupler weld area including the minimum leg length of the fillet weld E for forces of Type I and Type II for Grades 60 and 80. These use the minimum yield strength in the coupler of 64 ksi when determining the leg length on the coupler side.

**Table Appendix1. Dimensions for C2J and C3J with ACI318 Type I Forces for ASTM A615 Grade 60 Rebar (Note 1)**

Coupler Family	Part Number	Rebar Size		ØA		ØB		R		E		J	
		in-lbs	Metric	in.	[mm]	in.	[mm]	in.	[mm]	in.	[mm]	in.	[mm]
C2	EL12C2	#4	12	0.75	[19.1]	0.44	[11.2]	0.38	[9.7]	0.210	[5.34]	0.210	[5.34]
	EL14C2		14	1.00	[25.4]	0.56	[14.2]	0.38	[9.7]	0.113	[2.87]	0.113	[2.87]
	EL16C2	#5	16	1.00	[25.4]	0.56	[14.2]	0.38	[9.7]	0.229	[5.82]	0.229	[5.82]
C3J	EL18C3J		18	1.25	[31.8]	0.88	[22.4]	0.38	[9.7]	0.224	[5.69]	0.224	[5.69]
	EL20C3J	#6	20	1.25	[31.8]	0.88	[22.4]	0.38	[9.7]	0.267	[6.79]	0.267	[6.79]
	EL22C3J	#7	22	1.25	[31.8]	0.75	[19.1]	0.38	[9.7]	0.388	[9.86]	0.388	[9.86]
	EL25C3J	#8	25	1.56	[39.7]	1.00	[25.4]	0.38	[9.7]	0.391	[9.93]	0.391	[9.93]
	EL28C3J	#9	28	1.56	[39.7]	0.94	[23.9]	0.38	[9.7]	0.526	[13.35]	0.526	[13.35]
	EL32C3J	#10	32	2.00	[50.8]	0.94	[23.9]	0.38	[9.7]	0.449	[11.40]	0.449	[11.40]
	EL36C3J	#11	36	2.00	[50.8]	1.13	[28.7]	0.38	[9.7]	0.631	[16.04]	0.631	[16.04]
	EL38C3J	#12	38	2.38	[60.3]	1.41	[35.8]	0.38	[9.7]	0.555	[14.09]	0.555	[14.09]
	EL40C3J		40	2.38	[60.3]	1.41	[35.8]	0.38	[9.7]	0.642	[16.30]	0.642	[16.30]
	EL40TC3J		40	2.38	[60.3]	1.41	[35.8]	0.38	[9.7]	0.642	[16.30]	0.642	[16.30]
	EL43TC3J	#14	43	2.38	[60.3]	1.41	[35.8]	0.38	[9.7]	0.773	[19.63]	0.773	[19.63]
	EL50TC3J		50	2.75	[69.4]	1.50	[38.1]	0.38	[9.7]	0.902	[22.91]	0.902	[22.91]
EL57TC3J	#18	57	3.13	[79.4]	1.75	[44.5]	0.38	[9.7]	1.049	[26.65]	1.049	[26.65]	

Note 1: ASTM A615 grade 60 equals the force of ASTM A706 grade 60.

**Table Appendix2. Dimensions for C2 and C3J with ACI 318 Type II Forces for ASTM A615 Grade 60 Rebar (Note 1)**

Coupler Family	Part Number	Rebar Size		ØA		ØB		R		E		J	
		in-lbs	Metric	in.	[mm]	in.	[mm]	in.	[mm]	in.	[mm]	in.	[mm]
C2	EL12C2	#4	12	0.75	[19.1]	0.44	[11.2]	0.38	[9.7]	0.265	[6.73]	0.265	[6.73]
	EL14C2		14	1.00	[25.4]	0.56	[14.2]	0.38	[9.7]	0.199	[5.06]	0.199	[5.06]
	EL16C2	#5	16	1.00	[25.4]	0.56	[14.2]	0.38	[9.7]	0.297	[7.54]	0.297	[7.54]
C3J	EL18C3J		18	1.25	[31.8]	0.88	[22.4]	0.38	[9.7]	0.291	[7.39]	0.291	[7.39]
	EL20C3J	#6	20	1.25	[31.8]	0.88	[22.4]	0.38	[9.7]	0.340	[8.64]	0.340	[8.64]
	EL22C3J	#7	22	1.25	[31.8]	0.75	[19.1]	0.38	[9.7]	0.483	[12.27]	0.483	[12.27]
	EL25C3J	#8	25	1.56	[39.7]	1.00	[25.4]	0.38	[9.7]	0.495	[12.58]	0.495	[12.58]
	EL28C3J	#9	28	1.56	[39.7]	0.94	[23.9]	0.38	[9.7]	0.649	[16.49]	0.649	[16.49]
	EL32C3J	#10	32	2.00	[50.8]	0.94	[23.9]	0.38	[9.7]	0.615	[15.63]	0.615	[15.63]
	EL36C3J	#11	36	2.00	[50.8]	1.13	[28.7]	0.38	[9.7]	0.787	[20.00]	0.787	[20.00]
	EL38C3J	#12	38	2.38	[60.3]	1.41	[35.8]	0.38	[9.7]	0.713	[18.12]	0.713	[18.12]
	EL40C3J		40	2.38	[60.3]	1.41	[35.8]	0.38	[9.7]	0.811	[20.60]	0.811	[20.60]
	EL40TC3J		40	2.38	[60.3]	1.41	[35.8]	0.38	[9.7]	0.811	[20.60]	0.811	[20.60]
	EL43TC3J	#14	43	2.38	[60.3]	1.41	[35.8]	0.38	[9.7]	0.958	[24.34]	0.958	[24.34]
	EL50TC3J		50	2.75	[69.4]	1.50	[38.1]	0.38	[9.7]	1.122	[28.50]	1.122	[28.50]
EL57TC3J	#18	57	3.13	[79.4]	1.75	[44.5]	0.38	[9.7]	1.301	[33.04]	1.301	[33.04]	

Note 1: ASTM A615 grade 60 exceeds the force of ASTM A706 grade 60.

**Table Appendix3. Dimensions for C2 and C3J with ACI318 Type I Forces for ASTM A615 Grade 80 Rebar (Note 1)**

Coupler Family	Part Number	Rebar Size		ØA		ØB		R		E		J	
		in-lbs	Metric	in.	[mm]	in.	[mm]	in.	[mm]	in.	[mm]	in.	[mm]
C2	EL12C2	#4	12	0.75	[19.1]	0.44	[11.2]	0.38	[9.7]	0.299	[7.60]	0.299	[7.60]
	EL14C2		14	1.00	[25.4]	0.56	[14.2]	0.38	[9.7]	0.240	[6.11]	0.240	[6.11]
	EL16C2	#5	16	1.00	[25.4]	0.56	[14.2]	0.38	[9.7]	0.340	[8.62]	0.340	[8.62]
C3J	EL18C3J		18	1.25	[31.8]	0.88	[22.4]	0.38	[9.7]	0.334	[8.48]	0.334	[8.48]
	EL20C3J	#6	20	1.25	[31.8]	0.88	[22.4]	0.38	[9.7]	0.387	[9.83]	0.387	[9.83]
	EL22C3J	#7	22	1.25	[31.8]	0.75	[19.1]	0.38	[9.7]	0.543	[13.80]	0.543	[13.80]
	EL25C3J	#8	25	1.56	[39.7]	1.00	[25.4]	0.38	[9.7]	0.561	[14.26]	0.561	[14.26]
	EL28C3J	#9	28	1.56	[39.7]	0.94	[23.9]	0.38	[9.7]	0.727	[18.48]	0.727	[18.48]
	EL32C3J	#10	32	2.00	[50.8]	0.94	[23.9]	0.38	[9.7]	0.706	[17.92]	0.706	[17.92]
	EL36C3J	#11	36	2.00	[50.8]	1.13	[28.7]	0.38	[9.7]	0.886	[22.50]	0.886	[22.50]
	EL38C3J	#12	38	2.38	[60.3]	1.41	[35.8]	0.38	[9.7]	0.814	[20.67]	0.814	[20.67]
	EL40C3J		40	2.38	[60.3]	1.41	[35.8]	0.38	[9.7]	0.918	[23.32]	0.918	[23.32]
	EL40TC3J		40	2.38	[60.3]	1.41	[35.8]	0.38	[9.7]	0.918	[23.32]	0.918	[23.32]
	EL43TC3J	#14	43	2.38	[60.3]	1.41	[35.8]	0.38	[9.7]	1.076	[27.32]	1.076	[27.32]
	EL50TC3J		50	2.75	[69.4]	1.50	[38.1]	0.38	[9.7]	1.261	[32.03]	1.261	[32.03]
	EL57TC3J	#18	57	3.13	[79.4]	1.75	[44.5]	0.38	[9.7]	1.460	[37.08]	1.460	[37.08]

Note 1: ASTM A615 grade 80 exceeds or equals the force of ASTM A615 grade 75 and ASTM A706 grade 80

**Table Appendix4. Dimensions for C2 and C3J with ACI 318 Type II Forces for ASTM A615 Grade 80 Rebar (Note 1)**

Coupler Family	Part Number	Rebar Size		ØA		ØB		R		E		J	
		in-lbs	Metric	in.	[mm]	in.	[mm]	in.	[mm]	in.	[mm]	in.	[mm]
C2	EL12C2	#4	12	0.75	[19.1]	0.44	[11.2]	0.38	[9.7]	0.316	[8.03]	0.316	[8.03]
	EL14C2		14	1.00	[25.4]	0.56	[14.2]	0.38	[9.7]	0.258	[6.55]	0.258	[6.55]
	EL16C2	#5	16	1.00	[25.4]	0.56	[14.2]	0.38	[9.7]	0.360	[9.15]	0.360	[9.15]
C3J	EL18C3J		18	1.25	[31.8]	0.88	[22.4]	0.38	[9.7]	0.355	[9.01]	0.355	[9.01]
	EL20C3J	#6	20	1.25	[31.8]	0.88	[22.4]	0.38	[9.7]	0.410	[10.41]	0.410	[10.41]
	EL22C3J	#7	22	1.25	[31.8]	0.75	[19.1]	0.38	[9.7]	0.572	[14.54]	0.572	[14.54]
	EL25C3J	#8	25	1.56	[39.7]	1.00	[25.4]	0.38	[9.7]	0.593	[15.07]	0.593	[15.07]
	EL28C3J	#9	28	1.56	[39.7]	0.94	[23.9]	0.38	[9.7]	0.765	[19.44]	0.765	[19.44]
	EL32C3J	#10	32	2.00	[50.8]	0.94	[23.9]	0.38	[9.7]	0.749	[19.04]	0.749	[19.04]
	EL36C3J	#11	36	2.00	[50.8]	1.13	[28.7]	0.38	[9.7]	0.934	[23.71]	0.934	[23.71]
	EL38C3J	#12	38	2.38	[60.3]	1.41	[35.8]	0.38	[9.7]	0.863	[21.91]	0.863	[21.91]
	EL40C3J		40	2.38	[60.3]	1.41	[35.8]	0.38	[9.7]	0.970	[24.64]	0.970	[24.64]
	EL40TC3J		40	2.38	[60.3]	1.41	[35.8]	0.38	[9.7]	0.970	[24.64]	0.970	[24.64]
	EL43TC3J	#14	43	2.38	[60.3]	1.41	[35.8]	0.38	[9.7]	1.132	[28.76]	1.132	[28.76]
	EL50TC3J		50	2.75	[69.4]	1.50	[38.1]	0.38	[9.7]	1.328	[33.74]	1.328	[33.74]
	EL57TC3J	#18	57	3.13	[79.4]	1.75	[44.5]	0.38	[9.7]	1.537	[39.03]	1.537	[39.03]

Note 1: ASTM A615 grade 80 exceeds the force of ASTM A615 grade 75 and ASTM A706 grade 80

The shear stress for the adjacent coupler material is acceptable, using the coupler yield strength (64 ksi) and the frustrum cone from the weld root to the weld toe on the coupler.

For all cases the tensile stress on the face of the support member is less than 16 ksi. This will be less than the allowable stress for both A36 steel and for A572 Grade 50. Stresses should also be checked on the structural steel at the outer perimeter of the attachment to make sure that sufficient thickness of structural steel is available to carry the load transmitted as shear and bending stresses.

**P9J:**

Tables Appendix5 through Appendix8 show the dimensions of the coupler weld area including the minimum leg length of the fillet weld E for forces of Type I and Type II for Grades 60 and 80. These use the minimum yield strength in the coupler of 64 ksi when determining the leg length on the coupler side.

**Table Appendix5. Dimensions for P9J with ACI318 Type I Forces for ASTM A615 Grade 60 Rebar (Note 1)**

Coupler Family	Part Number	Rebar Size		ØA		ØB		R		E		J	
		in-lbs	Metric	in.	[mm]	in.	[mm]	in.	[mm]	in.	[mm]	in.	[mm]
P9J(3)	EL20P9J	#6	20	2.00	[50.8]	1.63	[41.3]	0.38	[9.7]	0.054	[1.37]	0.054	[1.37]
	EL22P9J	#7	22	2.00	[50.8]	1.50	[38.1]	0.38	[9.7]	0.116	[2.95]	0.116	[2.95]
	EL25P9J	#8	25	2.00	[50.8]	1.38	[34.9]	0.38	[9.7]	0.210	[5.33]	0.210	[5.33]
	EL28P9J	#9	28	3.00	[76.2]	2.50	[63.5]	0.38	[9.7]	0.151	[3.85]	0.151	[3.85]
	EL32P9J	#10	32	3.00	[76.2]	2.38	[60.3]	0.38	[9.7]	0.216	[5.49]	0.216	[5.49]
	EL36P9J	#11	36	3.00	[76.2]	2.25	[57.2]	0.38	[9.7]	0.296	[7.52]	0.296	[7.52]

Note 1: ASTM A615 grade 60 equals the force of ASTM A706 grade 60.

**Table Appendix6. Dimensions for P9J with ACI 318 Type II Forces for ASTM A615 Grade 60 Rebar (Note 1)**

Coupler Family	Part Number	Rebar Size		ØA		ØB		R		E		J	
		in-lbs	Metric	in.	[mm]	in.	[mm]	in.	[mm]	in.	[mm]	in.	[mm]
P9J(3)	EL20P9J	#6	20	2.00	[50.8]	1.63	[41.3]	0.38	[9.7]	0.140	[3.56]	0.140	[3.56]
	EL22P9J	#7	22	2.00	[50.8]	1.50	[38.1]	0.38	[9.7]	0.217	[5.50]	0.217	[5.50]
	EL25P9J	#8	25	2.00	[50.8]	1.38	[34.9]	0.38	[9.7]	0.324	[8.23]	0.324	[8.23]
	EL28P9J	#9	28	3.00	[76.2]	2.50	[63.5]	0.38	[9.7]	0.246	[6.25]	0.246	[6.25]
	EL32P9J	#10	32	3.00	[76.2]	2.38	[60.3]	0.38	[9.7]	0.330	[8.38]	0.330	[8.38]
	EL36P9J	#11	36	3.00	[76.2]	2.25	[57.2]	0.38	[9.7]	0.428	[10.86]	0.428	[10.86]

Note 1: ASTM A615 grade 60 exceeds the force of ASTM A706 grade 60.

**Table Appendix7. Dimensions for P9J with ACI318 Type I Forces for ASTM A615 Grade 80 Rebar (Note 1)**

Coupler Family	Part Number	Rebar Size		ØA		ØB		R		E		J	
		in-lbs	Metric	in.	[mm]	in.	[mm]	in.	[mm]	in.	[mm]	in.	[mm]
P9J(3)	EL20P9J	#6	20	2.00	[50.8]	1.63	[41.3]	0.38	[9.7]	0.180	[4.58]	0.180	[4.58]
	EL22P9J	#7	22	2.00	[50.8]	1.50	[38.1]	0.38	[9.7]	0.267	[6.79]	0.267	[6.79]
	EL25P9J	#8	25	2.00	[50.8]	1.38	[34.9]	0.38	[9.7]	0.383	[9.72]	0.383	[9.72]
	EL28P9J	#9	28	3.00	[76.2]	2.50	[63.5]	0.38	[9.7]	0.297	[7.53]	0.297	[7.53]
	EL32P9J	#10	32	3.00	[76.2]	2.38	[60.3]	0.38	[9.7]	0.393	[9.99]	0.393	[9.99]
	EL36P9J	#11	36	3.00	[76.2]	2.25	[57.2]	0.38	[9.7]	0.504	[12.81]	0.504	[12.81]

Note 1: ASTM A615 grade 80 exceeds or equals the force of ASTM A615 grade 75 and ASTM A706 grade 80

**Table Appendix8. Dimensions for P9J with ACI 318 Type II Forces for ASTM A615 Grade 80 Rebar (Note 1)**

Coupler Family	Part Number	Rebar Size		ØA		ØB		R		E		J	
		in-lbs	Metric	in.	[mm]	in.	[mm]	in.	[mm]	in.	[mm]	in.	[mm]
P9J(3)	EL20P9J	#6	20	2.00	[50.8]	1.63	[41.3]	0.38	[9.7]	0.198	[5.02]	0.198	[5.02]
	EL22P9J	#7	22	2.00	[50.8]	1.50	[38.1]	0.38	[9.7]	0.290	[7.36]	0.290	[7.36]
	EL25P9J	#8	25	2.00	[50.8]	1.38	[34.9]	0.38	[9.7]	0.411	[10.45]	0.411	[10.45]
	EL28P9J	#9	28	3.00	[76.2]	2.50	[63.5]	0.38	[9.7]	0.321	[8.16]	0.321	[8.16]
	EL32P9J	#10	32	3.00	[76.2]	2.38	[60.3]	0.38	[9.7]	0.424	[10.78]	0.424	[10.78]
	EL36P9J	#11	36	3.00	[76.2]	2.25	[57.2]	0.38	[9.7]	0.542	[13.76]	0.542	[13.76]

Note 1: ASTM A615 grade 80 exceeds the force of ASTM A615 grade 75 and ASTM A706 grade 80

The shear stress for the adjacent coupler material is acceptable, using the coupler yield strength (64 ksi) and the frustrum cone from the weld root to the weld toe on the coupler.

For all cases the tensile stress on the face of the support member is less than 14 ksi. This will be less than the allowable stress for both A36 steel and for A572 Grade 50. Stresses should also be checked on the structural steel at the outer perimeter of the attachment to make sure that sufficient thickness of structural steel is available to carry the load transmitted as shear and bending stresses.

**CADWELD B:**

Tables Appendix9 and Appendix10 show the dimensions of the coupler weld area including the minimum leg length of the fillet weld E for forces of Type I and Type II for Grades 60 and 80. These use the minimum yield strength in the coupler of 64 ksi when determining the leg length on the coupler side.

**Table Appendix9. Dimensions for CADWELD B with ACI318 Type I Forces for ASTM A615 Grade 60 Rebar (Note 1)**

Coupler Family	Part Number	Rebar Size		ØA		ØB		R		E		J	
		in-lbs	Metric	in.	[mm]	in.	[mm]	in.	[mm]	in.	[mm]	in.	[mm]
Cad weld Sleeve RBB xxxJA	RBB592JA	#4	12	1.38	[34.9]	1.04	[26.3]	0.38	[9.7]	0.000	[0.00]	0.000	[0.00]
	RBB592JA	#5	16	1.38	[34.9]	1.04	[26.3]	0.38	[9.7]	0.118	[2.99]	0.118	[2.99]
	RBB692JA	#6	20	1.50	[38.1]	1.16	[29.5]	0.38	[9.7]	0.202	[5.12]	0.202	[5.12]
	RBB792JA	#7	22	1.63	[41.3]	1.29	[32.6]	0.38	[9.7]	0.281	[7.15]	0.281	[7.15]
	RBB8101JA	#8	25	1.88	[47.6]	1.42	[36.0]	0.38	[9.7]	0.305	[7.73]	0.305	[7.73]
	RBB992JA	#9	28	2.13	[54.0]	1.67	[42.4]	0.38	[9.7]	0.352	[8.94]	0.352	[8.94]
	RBB1092JA	#10	32	2.25	[57.2]	1.79	[45.5]	0.38	[9.7]	0.449	[11.40]	0.449	[11.40]
	RBB11101JA	#11	36	2.50	[63.5]	1.93	[48.9]	0.38	[9.7]	0.481	[12.21]	0.481	[12.21]
	RBB14101JA	#14	43	3.00	[76.2]	2.31	[58.6]	0.38	[9.7]	0.577	[14.67]	0.577	[14.67]
RBB1892JA	#18	57	3.75	[95.3]	2.83	[71.8]	0.38	[9.7]	0.845	[21.46]	0.845	[21.46]	

Note 1: ASTM A615 grade 60 equals the force of ASTM A706 grade 60.

**Table Appendix10. Dimensions for CADWELD B with ACI 318 Type II Forces for ASTM A615 Grade 60 Rebar (Note 1)**

Coupler Family	Part Number	Rebar Size		ØA		ØB		R		E		J	
		in-lbs	Metric	in.	[mm]	in.	[mm]	in.	[mm]	in.	[mm]	in.	[mm]
Cad weld Sleeve RBB xxxJA	RBB592JA	#4	12	1.38	[34.9]	1.04	[26.3]	0.38	[9.7]	0.000	[0.00]	0.000	[0.00]
	RBB592JA	#5	16	1.38	[34.9]	1.04	[26.3]	0.38	[9.7]	0.180	[4.56]	0.180	[4.56]
	RBB692JA	#6	20	1.50	[38.1]	1.16	[29.5]	0.38	[9.7]	0.266	[6.75]	0.266	[6.75]
	RBB792JA	#7	22	1.63	[41.3]	1.29	[32.6]	0.38	[9.7]	0.358	[9.10]	0.358	[9.10]
	RBB8101JA	#8	25	1.88	[47.6]	1.42	[36.0]	0.38	[9.7]	0.395	[10.02]	0.395	[10.02]
	RBB992JA	#9	28	2.13	[54.0]	1.67	[42.4]	0.38	[9.7]	0.451	[11.45]	0.451	[11.45]
	RBB1092JA	#10	32	2.25	[57.2]	1.79	[45.5]	0.38	[9.7]	0.563	[14.30]	0.563	[14.30]
	RBB11101JA	#11	36	2.50	[63.5]	1.93	[48.9]	0.38	[9.7]	0.609	[15.47]	0.609	[15.47]
	RBB14101JA	#14	43	3.00	[76.2]	2.31	[58.6]	0.38	[9.7]	0.732	[18.59]	0.732	[18.59]
RBB1892JA	#18	57	3.75	[95.3]	2.83	[71.8]	0.38	[9.7]	1.059	[26.90]	1.059	[26.90]	

Note 1: ASTM A615 grade 60 exceeds the force of ASTM A706 grade 60.

The shear stress for the adjacent coupler material is acceptable, using the coupler yield strength (64 ksi) and the frustrum cone from the weld root to the weld toe on the coupler.

For all cases the tensile stress on the face of the support member is less than 16 ksi. This will be less than the allowable stress for both A36 steel and for A572 Grade 50. Stresses should also be checked on the structural steel at the outer perimeter of the attachment to make sure that sufficient thickness of structural steel is available to carry the load transmitted as shear and bending stresses.



**C13:**

Tables Appendix11 through Appendix14 show the dimensions of the coupler weld area including the minimum leg length of the fillet weld E for forces of Type I and Type II for Grades 60 and 80. These use the minimum yield strength in the coupler of 64 ksi when determining the leg length on the coupler side.

**Table Appendix11. Dimensions for C13 with ACI318 Type I Forces for ASTM A615 Grade 60 Rebar (Note 1)**

Coupler Family	Part Number	Rebar Size		ØA		ØB		R		E		J	
		in-lbs	Metric	in.	[mm]	in.	[mm]	in.	[mm]	in.	[mm]	in.	[mm]
C13	EL12C13	#4	12	0.75	[19.1]	0.44	[11.2]	0.39	[10.0]	0.210	[5.34]	0.210	[5.34]
	EL14C13	-	14	1.00	[25.4]	0.69	[17.5]	0.39	[10.0]	0.166	[4.21]	0.166	[4.21]
	EL16C13	#5	16	1.00	[25.4]	0.69	[17.5]	0.39	[10.0]	0.242	[6.14]	0.242	[6.14]
	EL18C13	-	18	1.25	[31.8]	0.94	[23.9]	0.39	[10.0]	0.236	[5.98]	0.236	[5.98]
	EL20C13	#6	20	1.25	[31.8]	0.88	[22.4]	0.39	[10.0]	0.267	[6.79]	0.267	[6.79]
	EL22C13	#7	22	1.25	[31.8]	0.63	[16.0]	0.39	[10.0]	0.387	[9.83]	0.387	[9.83]
	EL25C13	#8	25	1.56	[39.6]	0.94	[23.9]	0.39	[10.0]	0.387	[9.83]	0.387	[9.83]
	EL28C13	#9	28	1.56	[39.6]	0.63	[16.0]	0.39	[10.0]	0.539	[13.70]	0.539	[13.70]
	EL32C13	#10	32	2.00	[50.8]	1.25	[31.8]	0.39	[10.0]	0.485	[12.31]	0.485	[12.31]
	EL36C13	#11	36	2.00	[50.8]	0.88	[22.4]	0.39	[10.0]	0.639	[16.22]	0.639	[16.22]
	EL38C13	-	38	2.38	[60.5]	1.50	[38.1]	0.39	[10.0]	0.560	[14.23]	0.560	[14.23]
	EL40C13	-	40	2.38	[60.5]	1.25	[31.8]	0.39	[10.0]	0.634	[16.10]	0.634	[16.10]
	EL40TC13	-	40	2.38	[60.5]	1.41	[35.8]	0.39	[10.0]	0.639	[16.23]	0.639	[16.23]
	EL43TC13	#14	43	2.38	[60.5]	1.00	[25.4]	0.39	[10.0]	0.783	[19.89]	0.783	[19.89]
	EL50TC13	-	50	2.75	[69.9]	1.13	[28.7]	0.39	[10.0]	0.922	[23.41]	0.922	[23.41]
EL57TC13	#18	57	3.13	[79.5]	1.25	[31.8]	0.39	[10.0]	1.075	[27.29]	1.075	[27.29]	

Note 1: ASTM A615 grade 60 equals the force of ASTM A706 grade 60.

**Table Appendix12. Dimensions for C13 with ACI 318 Type II Forces for ASTM A615 Grade 60 Rebar (Note 1)**

Coupler Family	Part Number	Rebar Size		ØA		ØB		R		E		J	
		in-lbs	Metric	in.	[mm]	in.	[mm]	in.	[mm]	in.	[mm]	in.	[mm]
C13	EL12C13	#4	12	0.75	[19.1]	0.44	[11.2]	0.39	[10.0]	0.265	[6.73]	0.265	[6.73]
	EL14C13	-	14	1.00	[25.4]	0.69	[17.5]	0.39	[10.0]	0.218	[5.55]	0.218	[5.55]
	EL16C13	#5	16	1.00	[25.4]	0.69	[17.5]	0.39	[10.0]	0.305	[7.74]	0.305	[7.74]
	EL18C13	-	18	1.25	[31.8]	0.94	[23.9]	0.39	[10.0]	0.301	[7.63]	0.301	[7.63]
	EL20C13	#6	20	1.25	[31.8]	0.88	[22.4]	0.39	[10.0]	0.340	[8.64]	0.340	[8.64]
	EL22C13	#7	22	1.25	[31.8]	0.63	[16.0]	0.39	[10.0]	0.486	[12.35]	0.486	[12.35]
	EL25C13	#8	25	1.56	[39.6]	0.94	[23.9]	0.39	[10.0]	0.493	[12.53]	0.493	[12.53]
	EL28C13	#9	28	1.56	[39.6]	0.63	[16.0]	0.39	[10.0]	0.673	[17.09]	0.673	[17.09]
	EL32C13	#10	32	2.00	[50.8]	1.25	[31.8]	0.39	[10.0]	0.617	[15.68]	0.617	[15.68]
	EL36C13	#11	36	2.00	[50.8]	0.88	[22.4]	0.39	[10.0]	0.803	[20.39]	0.803	[20.39]
	EL38C13	-	38	2.38	[60.5]	1.50	[38.1]	0.39	[10.0]	0.716	[18.17]	0.716	[18.17]
	EL40C13	-	40	2.38	[60.5]	1.25	[31.8]	0.39	[10.0]	0.809	[20.54]	0.809	[20.54]
	EL40TC13	-	40	2.38	[60.5]	1.41	[35.8]	0.39	[10.0]	0.808	[20.53]	0.808	[20.53]
	EL43TC13	#14	43	2.38	[60.5]	1.00	[25.4]	0.39	[10.0]	0.982	[24.94]	0.982	[24.94]
	EL50TC13	-	50	2.75	[69.9]	1.13	[28.7]	0.39	[10.0]	1.154	[29.30]	1.154	[29.30]
EL57TC13	#18	57	3.13	[79.5]	1.25	[31.8]	0.39	[10.0]	1.342	[34.09]	1.342	[34.09]	

Note 1: ASTM A615 grade 60 exceeds the force of ASTM A706 grade 60.



**Table Appendix13. Dimensions for C13 with ACI318 Type I Forces for ASTM A615 Grade 80 Rebar (Note 1)**

Coupler Family	Part Number	Rebar Size		ØA		ØB		R		E		J	
		in-lbs	Metric	in.	[mm]	in.	[mm]	in.	[mm]	in.	[mm]	in.	[mm]
C13	EL12C13	#4	12	0.75	[19.1]	0.44	[11.2]	0.39	[10.0]	0.299	[7.60]	0.299	[7.60]
	EL14C13	-	14	1.00	[25.4]	0.69	[17.5]	0.39	[10.0]	0.252	[6.40]	0.252	[6.40]
	EL16C13	#5	16	1.00	[25.4]	0.69	[17.5]	0.39	[10.0]	0.345	[8.76]	0.345	[8.76]
	EL18C13	-	18	1.25	[31.8]	0.94	[23.9]	0.39	[10.0]	0.342	[8.69]	0.342	[8.69]
	EL20C13	#6	20	1.25	[31.8]	0.88	[22.4]	0.39	[10.0]	0.387	[9.83]	0.387	[9.83]
	EL22C13	#7	22	1.25	[31.8]	0.63	[16.0]	0.39	[10.0]	0.549	[13.93]	0.549	[13.93]
	EL25C13	#8	25	1.56	[39.6]	0.94	[23.9]	0.39	[10.0]	0.561	[14.24]	0.561	[14.24]
	EL28C13	#9	28	1.56	[39.6]	0.63	[16.0]	0.39	[10.0]	0.757	[19.22]	0.757	[19.22]
	EL32C13	#10	32	2.00	[50.8]	1.25	[31.8]	0.39	[10.0]	0.701	[17.82]	0.701	[17.82]
	EL36C13	#11	36	2.00	[50.8]	0.88	[22.4]	0.39	[10.0]	0.906	[23.01]	0.906	[23.01]
	EL38C13	-	38	2.38	[60.5]	1.50	[38.1]	0.39	[10.0]	0.814	[20.68]	0.814	[20.68]
	EL40C13	-	40	2.38	[60.5]	1.25	[31.8]	0.39	[10.0]	0.919	[23.34]	0.919	[23.34]
	EL40TC13	-	40	2.38	[60.5]	1.41	[35.8]	0.39	[10.0]	0.916	[23.26]	0.916	[23.26]
	EL43TC13	#14	43	2.38	[60.5]	1.00	[25.4]	0.39	[10.0]	1.107	[28.11]	1.107	[28.11]
EL50TC13	-	50	2.75	[69.9]	1.13	[28.7]	0.39	[10.0]	1.299	[33.00]	1.299	[33.00]	
EL57TC13	#18	57	3.13	[79.5]	1.25	[31.8]	0.39	[10.0]	1.510	[38.35]	1.510	[38.35]	

Note 1: ASTM A615 grade 80 exceeds or equals the force of ASTM A615 grade 75 and ASTM A706 grade 80

**Table Appendix14. Dimensions for C13 with ACI 318 Type II Forces for ASTM A615 Grade 80 Rebar (Note 1)**

Coupler Family	Part Number	Rebar Size		ØA		ØB		R		E		J	
		in-lbs	Metric	in.	[mm]	in.	[mm]	in.	[mm]	in.	[mm]	in.	[mm]
C13	EL12C13	#4	12	0.75	[19.1]	0.44	[11.2]	0.39	[10.0]	0.316	[8.03]	0.316	[8.03]
	EL14C13	-	14	1.00	[25.4]	0.69	[17.5]	0.39	[10.0]	0.269	[6.82]	0.269	[6.82]
	EL16C13	#5	16	1.00	[25.4]	0.69	[17.5]	0.39	[10.0]	0.364	[9.26]	0.364	[9.26]
	EL18C13	-	18	1.25	[31.8]	0.94	[23.9]	0.39	[10.0]	0.363	[9.21]	0.363	[9.21]
	EL20C13	#6	20	1.25	[31.8]	0.88	[22.4]	0.39	[10.0]	0.410	[10.41]	0.410	[10.41]
	EL22C13	#7	22	1.25	[31.8]	0.63	[16.0]	0.39	[10.0]	0.579	[14.70]	0.579	[14.70]
	EL25C13	#8	25	1.56	[39.6]	0.94	[23.9]	0.39	[10.0]	0.593	[15.07]	0.593	[15.07]
	EL28C13	#9	28	1.56	[39.6]	0.63	[16.0]	0.39	[10.0]	0.797	[20.25]	0.797	[20.25]
	EL32C13	#10	32	2.00	[50.8]	1.25	[31.8]	0.39	[10.0]	0.742	[18.86]	0.742	[18.86]
	EL36C13	#11	36	2.00	[50.8]	0.88	[22.4]	0.39	[10.0]	0.956	[24.28]	0.956	[24.28]
	EL38C13	-	38	2.38	[60.5]	1.50	[38.1]	0.39	[10.0]	0.862	[21.90]	0.862	[21.90]
	EL40C13	-	40	2.38	[60.5]	1.25	[31.8]	0.39	[10.0]	0.972	[24.70]	0.972	[24.70]
	EL40TC13	-	40	2.38	[60.5]	1.41	[35.8]	0.39	[10.0]	0.968	[24.58]	0.968	[24.58]
	EL43TC13	#14	43	2.38	[60.5]	1.00	[25.4]	0.39	[10.0]	1.167	[29.64]	1.167	[29.64]
EL50TC13	-	50	2.75	[69.9]	1.13	[28.7]	0.39	[10.0]	1.370	[34.79]	1.370	[34.79]	
EL57TC13	#18	57	3.13	[79.5]	1.25	[31.8]	0.39	[10.0]	1.591	[40.41]	1.591	[40.41]	

Note 1: ASTM A615 grade 80 exceeds the force of ASTM A615 grade 75 and ASTM A706 grade 80

The shear stress for the adjacent coupler material is acceptable, using the coupler yield strength (64 ksi) and the frustrum cone from the weld root to the weld toe on the coupler.

For all cases the tensile stress on the face of the support member is less than 16 ksi. This will be less than the allowable stress for both A36 steel and for A572 Grade 50. Stresses should also be checked on the structural steel at the outer perimeter of the attachment to make sure that sufficient thickness of structural steel is available to carry the load transmitted as shear and bending stresses.

**C14:**

Tables Appendix15 through Appendix18 show the dimensions of the coupler weld area including the minimum leg length of the fillet weld E for forces of Type I and Type II for Grades 60 and 80. These use the minimum yield strength in the coupler of 50.8 ksi for sizes from EL10C14 to EL18C14 of 50.0 ksi for sizes from EL18C14 to EL32C14 and 47.1 ksi for sizes from EL34C14 to EL57C14 when determining the leg length on the coupler side.

**Table Appendix15. Dimensions for C14 with ACI318 Type I Forces for ASTM A615 Grade 60 Rebar (Note 1)**

Coupler Family	Part Number	Rebar Size		ØA		ØB		R		E		J	
		in-lbs	Metric	in.	[mm]	in.	[mm]	in.	[mm]	in.	[mm]	in.	[mm]
C14	EL10C14	#3	10	1.00	[25.4]	0.69	[17.5]	0.35	[9.0]	0.000	[0.00]	0.000	[0.00]
	EL12C14	#4	12	1.25	[31.8]	0.94	[23.9]	0.35	[9.0]	0.000	[0.00]	0.000	[0.00]
	EL14C14	-	14	1.25	[31.8]	0.88	[22.4]	0.35	[9.0]	0.000	[0.00]	0.000	[0.00]
	EL16C14	#5	16	1.50	[38.1]	1.19	[30.2]	0.35	[9.0]	0.000	[0.00]	0.000	[0.00]
	EL18C14	-	18	1.50	[38.1]	1.13	[28.7]	0.35	[9.0]	0.000	[0.00]	0.000	[0.00]
	EL20C14	#6	20	1.75	[44.5]	1.38	[35.1]	0.35	[9.0]	0.000	[0.00]	0.000	[0.00]
	EL22C14	#7	22	1.75	[44.5]	1.25	[31.8]	0.35	[9.0]	0.000	[0.00]	0.000	[0.00]
	EL25C14	#8	25	2.00	[50.8]	1.44	[36.6]	0.35	[9.0]	0.000	[0.00]	0.000	[0.00]
	EL28C14	#9	28	2.25	[57.2]	1.63	[41.4]	0.35	[9.0]	0.000	[0.00]	0.000	[0.00]
	EL30C14	-	30	2.50	[63.5]	1.88	[47.8]	0.35	[9.0]	0.000	[0.00]	0.000	[0.00]
	EL32C14	#10	32	2.50	[63.5]	1.75	[44.5]	0.35	[9.0]	0.000	[0.00]	0.000	[0.00]
	EL34C14	-	34	2.50	[63.5]	1.75	[44.5]	0.35	[9.0]	0.000	[0.00]	0.000	[0.00]
	EL36C14	#11	36	2.50	[63.5]	1.63	[41.4]	0.35	[9.0]	0.000	[0.00]	0.000	[0.00]
	EL38C14	-	38	3.00	[76.2]	2.25	[57.2]	0.35	[9.0]	0.000	[0.00]	0.000	[0.00]
	EL40C14	-	40	3.00	[76.2]	2.13	[54.1]	0.35	[9.0]	0.000	[0.00]	0.000	[0.00]
	EL43TC14	#14	43	3.25	[82.6]	2.25	[57.2]	0.35	[9.0]	0.000	[0.00]	0.000	[0.00]
	EL50TC14	-	50	3.75	[95.3]	2.63	[66.7]	0.35	[9.0]	0.000	[0.00]	0.000	[0.00]
EL57TC14	#18	57	4.00	[101.6]	2.63	[66.8]	0.35	[9.0]	0.500	[12.70]	0.835	[21.22]	

Note 1: ASTM A615 grade 60 equals the force of ASTM A706 grade 60.

**Table Appendix16. Dimensions for C14 with ACI 318 Type II Forces for ASTM A615 Grade 60 Rebar (Note 1)**

Coupler Family	Part Number	Rebar Size		ØA		ØB		R		E		J	
		in-lbs	Metric	in.	[mm]	in.	[mm]	in.	[mm]	in.	[mm]	in.	[mm]
C14	EL10C14	#3	10	1.00	[25.4]	0.69	[17.5]	0.35	[9.0]	0.000	[0.00]	0.000	[0.00]
	EL12C14	#4	12	1.25	[31.8]	0.94	[23.9]	0.35	[9.0]	0.084	[2.13]	0.084	[2.13]
	EL14C14	-	14	1.25	[31.8]	0.88	[22.4]	0.35	[9.0]	0.114	[2.90]	0.114	[2.90]
	EL16C14	#5	16	1.50	[38.1]	1.19	[30.2]	0.35	[9.0]	0.159	[4.04]	0.159	[4.04]
	EL18C14	-	18	1.50	[38.1]	1.13	[28.7]	0.35	[9.0]	0.215	[5.46]	0.215	[5.46]
	EL20C14	#6	20	1.75	[44.5]	1.38	[35.1]	0.35	[9.0]	0.197	[5.01]	0.197	[5.01]
	EL22C14	#7	22	1.75	[44.5]	1.25	[31.8]	0.35	[9.0]	0.289	[7.33]	0.289	[7.33]
	EL25C14	#8	25	2.00	[50.8]	1.44	[36.6]	0.35	[9.0]	0.336	[8.55]	0.336	[8.55]
	EL28C14	#9	28	2.25	[57.2]	1.63	[41.4]	0.35	[9.0]	0.381	[9.67]	0.381	[9.67]
	EL30C14	-	30	2.50	[63.5]	1.88	[47.8]	0.35	[9.0]	0.366	[9.31]	0.366	[9.31]
	EL32C14	#10	32	2.50	[63.5]	1.75	[44.5]	0.35	[9.0]	0.430	[10.92]	0.430	[10.92]
	EL34C14	-	34	2.50	[63.5]	1.75	[44.5]	0.35	[9.0]	0.504	[12.79]	0.606	[15.40]
	EL36C14	#11	36	2.50	[63.5]	1.63	[41.4]	0.35	[9.0]	0.564	[14.33]	0.685	[17.40]
	EL38C14	-	38	3.00	[76.2]	2.25	[57.2]	0.35	[9.0]	0.516	[13.10]	0.615	[15.62]
	EL40C14	-	40	3.00	[76.2]	2.13	[54.1]	0.35	[9.0]	0.575	[14.60]	0.691	[17.56]
	EL43TC14	#14	43	3.25	[82.6]	2.25	[57.2]	0.35	[9.0]	0.597	[15.16]	0.723	[18.36]
	EL50TC14	-	50	3.75	[95.3]	2.63	[66.7]	0.35	[9.0]	0.709	[18.02]	0.856	[21.75]
EL57TC14	#18	57	4.00	[101.6]	2.63	[66.8]	0.35	[9.0]	0.908	[23.05]	1.101	[27.96]	

Note 1: ASTM A615 grade 60 exceeds the force of ASTM A706 grade 60.

**Table Appendix17. Dimensions for C14 with ACI318 Type I Forces for ASTM A615 Grade 80 Rebar (Note 1)**

Coupler Family	Part Number	Rebar Size		ØA		ØB		R		E		J	
		in-lbs	Metric	in.	[mm]	in.	[mm]	in.	[mm]	in.	[mm]	in.	[mm]
C14	EL10C14	#3	10	1.00	[25.4]	0.69	[17.5]	0.35	[9.0]	0.000	[0.00]	0.000	[0.00]
	EL12C14	#4	12	1.25	[31.8]	0.94	[23.9]	0.35	[9.0]	0.120	[3.04]	0.120	[3.04]
	EL14C14	-	14	1.25	[31.8]	0.88	[22.4]	0.35	[9.0]	0.155	[3.94]	0.155	[3.94]
	EL16C14	#5	16	1.50	[38.1]	1.19	[30.2]	0.35	[9.0]	0.190	[4.82]	0.190	[4.82]
	EL18C14	-	18	1.50	[38.1]	1.13	[28.7]	0.35	[9.0]	0.253	[6.43]	0.253	[6.43]
	EL20C14	#6	20	1.75	[44.5]	1.38	[35.1]	0.35	[9.0]	0.235	[5.96]	0.235	[5.96]
	EL22C14	#7	22	1.75	[44.5]	1.25	[31.8]	0.35	[9.0]	0.339	[8.61]	0.339	[8.61]
	EL25C14	#8	25	2.00	[50.8]	1.44	[36.6]	0.35	[9.0]	0.394	[10.00]	0.434	[11.02]
	EL28C14	#9	28	2.25	[57.2]	1.63	[41.4]	0.35	[9.0]	0.445	[11.30]	0.490	[12.44]
	EL30C14	-	30	2.50	[63.5]	1.88	[47.8]	0.35	[9.0]	0.431	[10.94]	0.472	[11.99]
	EL32C14	#10	32	2.50	[63.5]	1.75	[44.5]	0.35	[9.0]	0.504	[12.81]	0.558	[14.17]
	EL34C14	-	34	2.50	[63.5]	1.75	[44.5]	0.35	[9.0]	0.584	[14.83]	0.698	[17.72]
	EL36C14	#11	36	2.50	[63.5]	1.63	[41.4]	0.35	[9.0]	0.653	[16.58]	0.790	[20.07]
	EL38C14	-	38	3.00	[76.2]	2.25	[57.2]	0.35	[9.0]	0.600	[15.23]	0.707	[17.96]
	EL40C14	-	40	3.00	[76.2]	2.13	[54.1]	0.35	[9.0]	0.667	[16.95]	0.796	[20.23]
	EL43TC14	#14	43	3.25	[82.6]	2.25	[57.2]	0.35	[9.0]	0.697	[17.71]	0.839	[21.31]
EL50TC14	-	50	3.75	[95.3]	2.63	[66.7]	0.35	[9.0]	0.826	[20.97]	0.990	[25.14]	
EL57TC14	#18	57	4.00	[101.6]	2.63	[66.8]	0.35	[9.0]	1.049	[26.64]	1.267	[32.18]	

Note 1: ASTM A615 grade 80 exceeds or equals the force of ASTM A615 grade 75 and ASTM A706 grade 80

**Table Appendix18. Dimensions for C14 with ACI 318 Type II Forces for ASTM A615 Grade 80 Rebar (Note 1)**

Coupler Family	Part Number	Rebar Size		ØA		ØB		R		E		J	
		in-lbs	Metric	in.	[mm]	in.	[mm]	in.	[mm]	in.	[mm]	in.	[mm]
C14	EL10C14	#3	10	1.00	[25.4]	0.69	[17.5]	0.35	[9.0]	0.000	[0.00]	0.000	[0.00]
	EL12C14	#4	12	1.25	[31.8]	0.94	[23.9]	0.35	[9.0]	0.135	[3.43]	0.135	[3.43]
	EL14C14	-	14	1.25	[31.8]	0.88	[22.4]	0.35	[9.0]	0.173	[4.41]	0.173	[4.41]
	EL16C14	#5	16	1.50	[38.1]	1.19	[30.2]	0.35	[9.0]	0.205	[5.21]	0.205	[5.21]
	EL18C14	-	18	1.50	[38.1]	1.13	[28.7]	0.35	[9.0]	0.272	[6.91]	0.272	[6.91]
	EL20C14	#6	20	1.75	[44.5]	1.38	[35.1]	0.35	[9.0]	0.253	[6.43]	0.253	[6.43]
	EL22C14	#7	22	1.75	[44.5]	1.25	[31.8]	0.35	[9.0]	0.363	[9.23]	0.401	[10.18]
	EL25C14	#8	25	2.00	[50.8]	1.44	[36.6]	0.35	[9.0]	0.422	[10.72]	0.464	[11.80]
	EL28C14	#9	28	2.25	[57.2]	1.63	[41.4]	0.35	[9.0]	0.477	[12.11]	0.524	[13.30]
	EL30C14	-	30	2.50	[63.5]	1.88	[47.8]	0.35	[9.0]	0.463	[11.75]	0.506	[12.84]
	EL32C14	#10	32	2.50	[63.5]	1.75	[44.5]	0.35	[9.0]	0.541	[13.73]	0.598	[15.18]
	EL34C14	-	34	2.50	[63.5]	1.75	[44.5]	0.35	[9.0]	0.623	[15.82]	0.742	[18.86]
	EL36C14	#11	36	2.50	[63.5]	1.63	[41.4]	0.35	[9.0]	0.696	[17.68]	0.841	[21.36]
	EL38C14	-	38	3.00	[76.2]	2.25	[57.2]	0.35	[9.0]	0.641	[16.27]	0.752	[19.10]
	EL40C14	-	40	3.00	[76.2]	2.13	[54.1]	0.35	[9.0]	0.713	[18.11]	0.848	[21.53]
	EL43TC14	#14	43	3.25	[82.6]	2.25	[57.2]	0.35	[9.0]	0.746	[18.96]	0.895	[22.74]
EL50TC14	-	50	3.75	[95.3]	2.63	[66.7]	0.35	[9.0]	0.883	[22.42]	1.055	[26.79]	
EL57TC14	#18	57	4.00	[101.6]	2.63	[66.8]	0.35	[9.0]	1.118	[28.39]	1.348	[34.25]	

Note 1: ASTM A615 grade 80 exceeds the force of ASTM A615 grade 75 and ASTM A706 grade 80

The weld sizes for C14 couplers are set by the requirement for the fillet height along the coupler size. Where fillets are required greater than the bevel size, a minimum value of *E* of 0.25 in. has been chosen so the fillets can be effectively tapered onto the supporting member. This is increased to 0.50 in. when the leg on the coupler exceeds 0.75 in. so that the ratio of the fillet legs *J* and *E* does not exceed 3.

For all cases the tensile stress on the face of the support member is less than 15 ksi. This will be less than the allowable stress for both A36 steel and for A572 Grade 50. Stresses should also be checked on the structural steel at the outer perimeter of the attachment to make sure that sufficient thickness of structural steel is available to carry the load transmitted as shear and bending stresses.